

K14 System and Termination Enclosure



The Compact 200 Series I/O subsystem has enclosures specifically designed to reduce the volume that the system requires in your plant. The K14 System and Termination Enclosure, is a highly space efficient design for mounting, powering, and providing communications to the system.

OVERVIEW

The K14 enclosure is specifically designed for housing Compact 200 Series I/O subsystem modules and their associated termination assemblies and customer-supplied terminal blocks for marshalling. The K14 vented enclosure is only available with roof-mounted fans.

The K14 vented enclosure can be configured with:

- ▶ Up to six Compact 200 Series 16-slot horizontal baseplates, for mounting up to 96 Compact 200 Series Fieldbus Modules (FBMs)
- ▶ Up to four 1900 mm vertical DIN rails for mounting of termination assemblies (TAs) and terminal blocks for marshalling; a total of 7.6 m (24.9 ft) of linear rail length
- ▶ One 2-position vertically-mounted FCP280 baseplate
- ▶ Up to two redundant FPS480-24 power supplies (four total) to support the 200 Series baseplates
- ▶ One redundant FPS480-24 power supply (two total) for field I/O.

The K14 vented enclosure is a free-standing, floor mounted unit with an IP 43 rating for location in mild (ordinary) environmental areas. It is available with two fans in a pagoda fan system and two fan trays to achieve the best cooling performance.

Multiple K-Series enclosures, including this enclosure and the K11 termination enclosure, can be installed connected to one another to minimize the required floor space and ease of cabling. This is achieved using baying kits as discussed in the *K-Series Enclosures Site Planning and Installation User's Guide* (B0700GN)

The rear of the K14 enclosure can be set up in one of two configurations:

- ▶ Termination only - all DIN rails are allocated for the mounting of termination assemblies only, where the customer terminates field signals directly to the termination assemblies.
- ▶ Marshalling - all DIN rails are set up in pairs of termination assemblies and terminal blocks to provide additional functionality (such as fusing, disconnects, and lock-out validation) or where customers wish to terminate field cable bundles to dedicated terminal blocks and marshall signals to the appropriate termination assemblies.

As well, this enclosure and its configurations have been tested and qualified for use with specified Compact 200 Series I/O products.

FEATURES

The Foxboro Evo™ K14 system and termination enclosure offers the following features:

- ▶ Accommodates one 2-position vertically-mounted Field Control Processor 280 baseplate
- ▶ Vented enclosure front accommodates up to 96 Compact 200 Series Fieldbus modules (FBMs) in up to six Compact 200 Series 16-slot horizontal baseplates

- ▶ Vented enclosure rear accommodates up to four 1900 mm vertical DIN rails for mounting of termination assemblies and terminal blocks for marshalling, to provide a total of 7.6 m (24.9 ft) of linear rail length
- ▶ Vented enclosure for use in ordinary (IP 43) environments
- ▶ Compact design to minimize use of floor space with both front and rear access that allows for the maximum density of enclosures in a control room environment
- ▶ Generous 76 mm x 102 mm (3 in x 4 in) wire ducts with adequate capacity for most wire management
- ▶ Option for single or redundant main and field I/O FPS480-24 power supplies
- ▶ Bottom cable entry for field and power wiring
- ▶ Conveniently placed eyebolts for transporting and lifting the enclosures
- ▶ A 100 mm (4 in) plinth - total enclosure height of 2160 mm (85.0 in)
- ▶ Comfort door handles with push-button or keylocks
- ▶ Standard protective earth (ground) studs and isolated instrument earth (ground) rail.

CONTAMINATION PROTECTION

The metal enclosures provide the outer layer of protection for the control electronics. Other layers are provided by the module covers and conformal coated electronics. This approach to protection means that a minimum of contaminants in the plant environment reaches the control components, thus greatly extending the life of the equipment.

The enclosures support bottom cable entry for field I/O cabling and power wiring.

THERMAL PROTECTION

This enclosure can be located in main equipment areas or in an environment with office air quality.

Two high-speed roof-mounted fans in a pagoda fan unit and two fan trays as well as vented doors increase air circulation for heat removal from the enclosure and can be used:

- ▶ At installations with only moderate levels of airborne contaminants, enclosure interiors can be exposed to allow plant air to circulate and remove module generated heat
- ▶ In areas where there are no requirements to filter the cooling air.

DUAL TEMPERATURE THERMOSTAT

An optional dual (high/low) thermostat is available to monitor enclosure temperature extremes, but not for use in Zone 2/Class I, Division 2 hazardous locations.

200 SERIES BASEPLATE MOUNTING

The enclosure can contain Compact 200 Series 16-slot horizontal baseplates and FCP280 baseplate, to accommodate Compact 200 Series FBMs and FCP280s respectively.

For more information on the Compact 200 Series 16-slot horizontal baseplate, refer to *Compact 200 Series 16-Slot Horizontal Baseplate* (PSS 31H-2C200).

For more information on the vertically-mounted FCP280 baseplate (RH924YF), refer to *Standard 200 Series Baseplates* (PSS 31H-2SBASPLT).

FIELDBUS I/O GROUPS

The K14 system and termination enclosure has two vertical punched rails accessed from the front of the enclosure for mounting up to six Compact 200 Series baseplates and up to four vertical DIN rails accessed from the rear for termination assemblies and customer-supplied terminal blocks for marshalling.

Each Compact 200 Series baseplate is mounted on dedicated DIN rail fitted on bar ladders. The vertically-mounted Field Control Processor 280 (FCP280) baseplate (RH924YF) and the FPS480-24 power supplies are mounted on designated locations as shown in Figure 2 and Figure 3. In the K14 enclosure, the baseplates are electrically connected so that they are divided into one of four separate Fieldbus I/O Groups. These I/O groups are organized as described in Table 1.

Table 1. Fieldbus I/O Groups in K14 Enclosure

Fieldbus I/O Group	Equipment in Enclosure Front - Managed by FCP280 ^(a)	Power Supplies	
1	Compact 200 Series Baseplate 1	Power Supply #1 (optionally redundant) feeds these three Compact 200 Series Baseplates and the FCP280 baseplate	
	Compact 200 Series Baseplate 2		
2	Compact 200 Series Baseplate 3		
	Compact 200 Series Baseplate 4		Power Supply #2 (optionally redundant) feeds these three Compact 200 Series Baseplates
3	Compact 200 Series Baseplate 5		
4	Compact 200 Series Baseplate 6		

(a) FCP280 may be single or redundant.

The FCP280 baseplate supports four HDLC module Fieldbuses, and each HDLC module Fieldbus supports up to two Compact 200 Series baseplates. Table 1 above explains how the Compact 200 Series baseplates are arranged from their FCP280's perspective. In this table, the baseplates in each Fieldbus I/O Group are part of the same baseplate chain.

TERMINATION ASSEMBLY MOUNTING

The K14 enclosure has up to four vertical DIN rails in the rear of the enclosure for mounting termination assemblies and customer-supplied terminal blocks for marshalling. Two are mounted in the center of the enclosure, and two are mounted on the sides.

Be aware that it may not be possible to add marshalling to this enclosure, depending on the size of the termination assemblies required in this enclosure.

Bus bars for field wiring shields and DIN rail isolation are available. These are used when customer field wire shields are terminated on dedicated terminal blocks that ground to the DIN rail. Isolation allows rails to be isolated from the enclosure earth.

An optionally redundant FPS480-24 field power supply is available for field power, and is mounted on side rails of the enclosure (see Figure 2). The K14 enclosure has a limited thermal load (see "Operating Temperatures" on page 10).

TERMINATION ASSEMBLY/INPUT POWER CABLING AND WIREWAYS

The enclosures support bottom cable entry only. The field I/O cables and power cable enter through removable gland plates, located at the bottom (inside) of the enclosure,

Cable straps are provided in the enclosure to dress and support the termination assembly cables. Field I/O signals must be connected to the TA mounted in the same enclosure or an adjoining termination enclosure.

Isolated ground bus bars for field wiring shields and DIN rail isolation are available. Isolation allows rails to be isolated from the enclosure earth.

POWER AND EARTHING (GROUNDING)

The K14 enclosure supports an optional redundant power system, in which dual power distribution (two power supplies fed by independent entry sources) provides redundancy protection against power failures.

Power wiring to the enclosure is routed through the bottom of the enclosure. Optional dual power input feeds terminate at dedicated primary and secondary power distribution terminal blocks.

All enclosure structural elements are integrally earthed by the enclosure design to meet the appropriate industry regulations and standards.

The K14 enclosure uses FPS480-24 power supplies that provide 24 V dc to 200 Series baseplates. These power supplies are agency certified for use in Zone II, Class I, Division 2 applications. For more information, refer to *Compact Power Supply - FPS480-24* (PSS 31H-2C480 B4).

Two studs (M8 size, one for each enclosure side) provide a central earth (ground) point and dedicated earthing points when baying enclosures together.

Power Distribution

Three power distribution terminal block assemblies (primary, secondary or utility for powering fans and lights, see Figure 2) have dedicated ring lug terminal blocks for customer main power. Each also can have fused, knife disconnect terminal blocks for interrupting the main power, as well as independent knife disconnect terminal blocks for each device, for ease of service.

Additional blocks are provided for the customer to install utility outlets.

The enclosure is available without these power distribution terminal blocks if required by the customer.

K14 Marshalling Layout and DIN Rail Identification

Termination Assembly and Associated Terminal Blocks (per configuration)

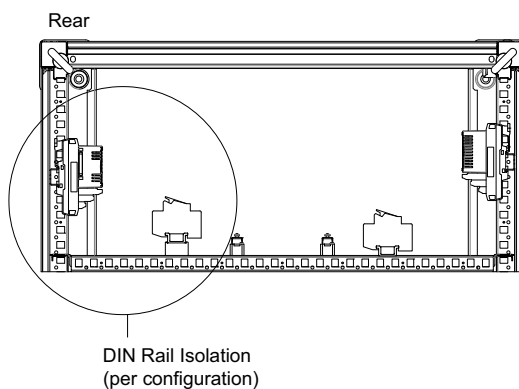

K14 Termination Layout and DIN Rail Identification

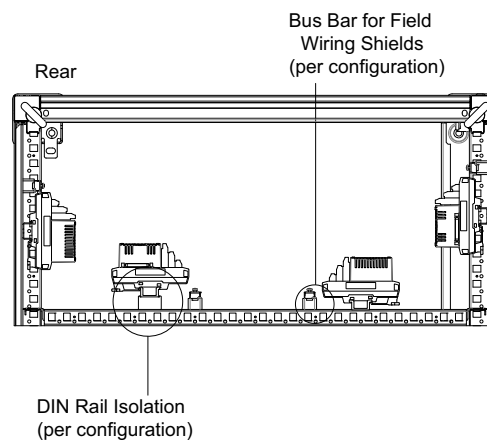

Figure 1. K14 Enclosure Termination and Marshalling Layouts and DIN Rail Identification

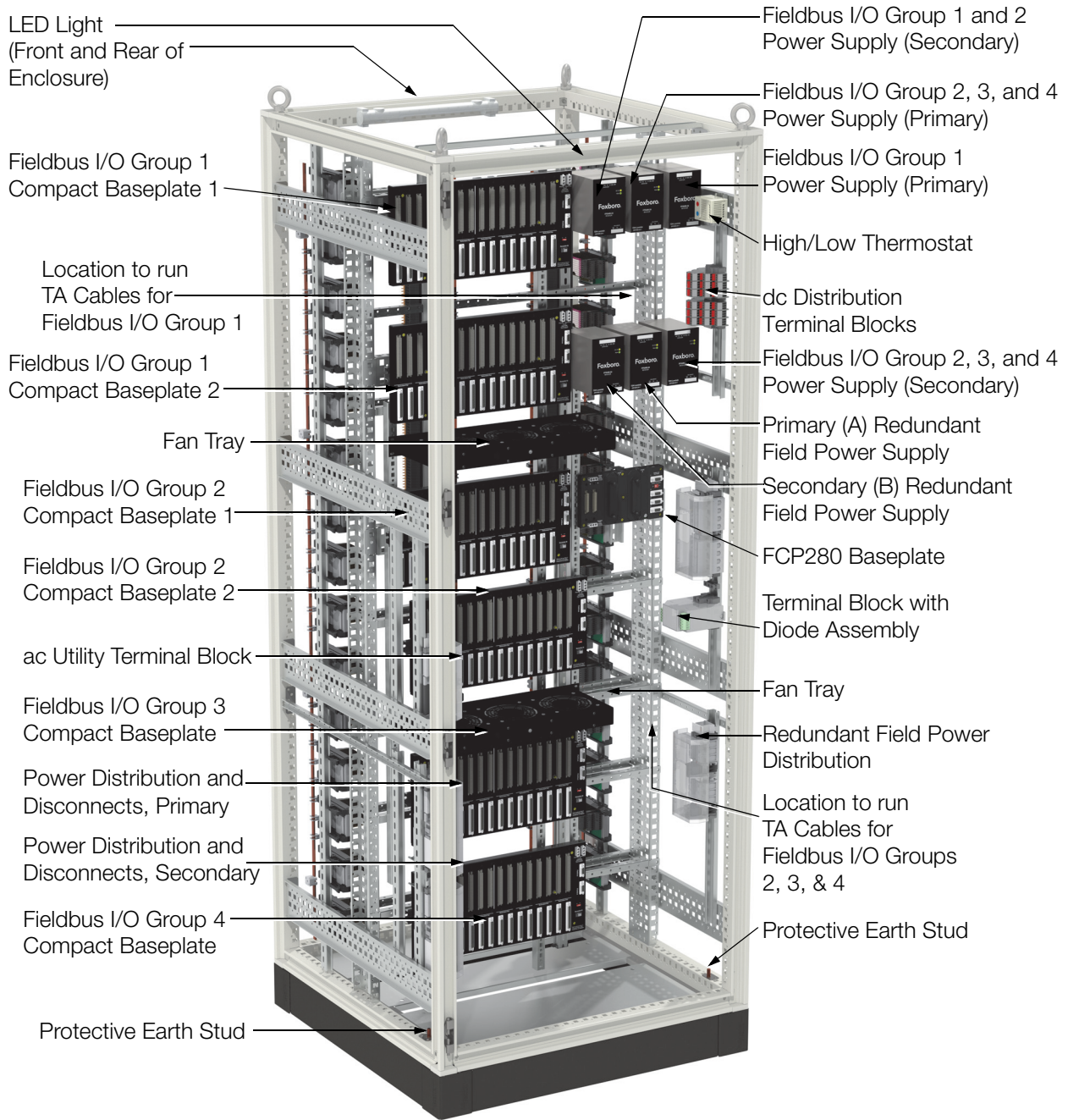

Figure 2. K14 System and Termination Enclosure, Front View

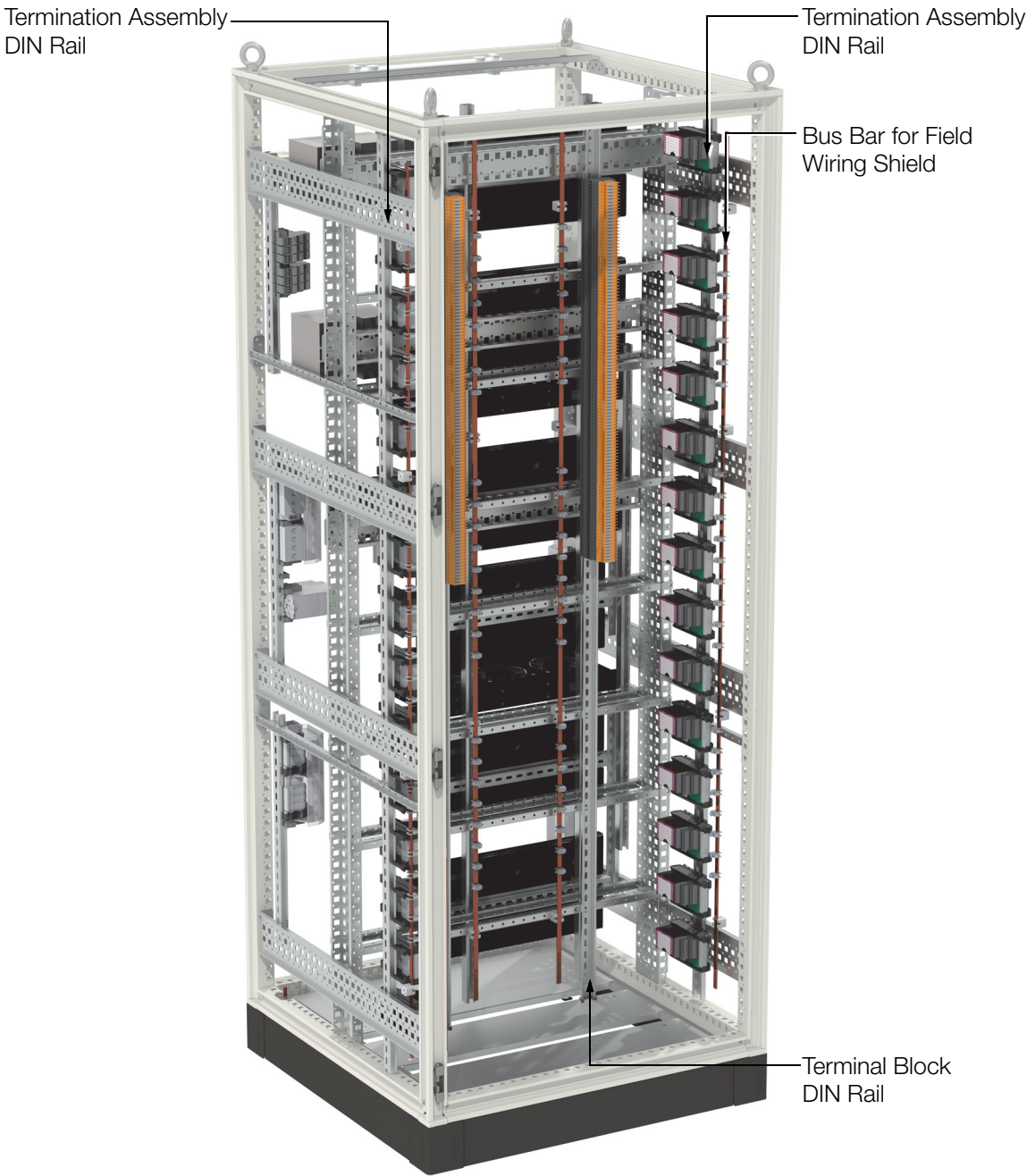

Figure 3. K14 System and Termination Enclosure, Rear View

ENCLOSURE FEATURES AND OPTIONS

The K14 enclosure is provided with the following features, some of which are optional.

Table 2. K14 Enclosure Features and Options

Feature	Availability
Base Enclosure	Vented IP 43 rated enclosure with roof-mounted fan (120 V ac or 240 V ac)
Enclosure Access	Front and rear access
Front Door	Solid front door with inlet vents
Cable Entry	Bottom cable entry
Sidewalls	Options configurable based on buying requirements
Door Handle	Handle with push-button or keylocks
Door Mounting	Universal mounting for left and right-hand door swing (left-hand is default)
Equipment Supported	Up to six horizontally mounted Compact 200 Series 16-Slot Horizontal Baseplates for mounting up to 96 Compact 200 Series FBMs One 2-position vertically-mounted FCP280 baseplate Up to four vertical DIN rails for mounting of termination assemblies (TAs) and terminal blocks for marshalling Single or redundant FPS480-24 power supplies to support the baseplates.
Field Wiring	Bus bars for field wiring shields and/or DIN rail isolation.
Enclosure Lighting ^(a)	Single and/or dual enclosure LED lights with motion activation
Thermostat ^(a)	Dual temperature thermostat
Fans ^(a)	Two physical fans in a pagoda fan unit (roof-mounted) and two fan trays (installed on punched rails)
Earthing (Grounding) ^(a)	Two protective earth (ground) studs Isolated instrument rail for additional connectors
Main Power ^(a)	85 to 264 V ac or 120 to 240 V dc nominal, 108 to 119 V dc (output derates to 90%) primary only or primary and secondary power (via up to two optionally redundant FPS480-24 power supplies) Terminal blocks supplied as per configuration.

Table 2. K14 Enclosure Features and Options (Continued)

Feature	Availability
Field Power	<p>Single or redundant FPS480-24 field power supply, 85 to 264 V ac or 120 to 240 V dc nominal, 108 to 119 V dc (output derates to 90%) input, or</p> <p>Single or redundant power distribution terminal block assemblies for customer configured power entry</p> <p>Additionally, customer-configured field power entry is supported. Terminal blocks supplied as per configuration.</p>
Utility Power	120 V ac or 240 V ac utility power terminal block

(a) To determine if this K-Series enclosure is acceptable to install in your application, refer to *Standard and Compact 200 Series I/O - Agency Certifications* (PSS 31H-2CERTS) to determine equipment location suitability.

FUNCTIONAL SPECIFICATIONS

Enclosure

The enclosures are free-standing, floor mounted, steel industrial enclosures containing:

- ▶ Up to six Compact 200 Series 16-slot horizontal baseplates for mounting up to 96 Compact 200 Series FBMs
- ▶ One 2-position vertically-mounted FCP280 baseplate

- ▶ Up to four vertical DIN rails for mounting of termination assemblies (TAs) and terminal blocks for marshalling
- ▶ Up to two redundant FPS480-24 power supplies (four total).

Input Power (Optionally Redundant)

Refer to *Compact Power Supply - FPS480-24*, (PSS 31H-2C480 B4).

ENVIRONMENTAL SPECIFICATIONS

Ingress Protection Ratings

IP 43 to EN 60 529/10.9191 / NEMA 12

Operating Temperatures

VENTED (THERMAL LOADING) WITH FANS

-20 to +55°C (-4 to +131°F)
Up to 1000 Watts (Maximum)

Storage Temperature

-40 to 70°C (40 to 158°F)

Relative Humidity

5 to 95% (noncondensing)

Dual Temperature Thermostat (User Settable)

HIGH ALARM SETTING

NC contact, Range - 0 to 60°C (32 to 140°F)

LOW ALARM SETTING

NO contact, Range - 0 to 60°C (32 to 140°F)

Acoustic Noise Level⁽¹⁾

ROOF-MOUNTED FANS WITH FAN TRAYS

64 dB (A) at 1 m / 62 dB (A) at 3 m

Table 3. Fan Tray Specifications (Continued)

Specification	115 V ac	230 V ac
Rated Speed (RPM)	3000	3000
Airflow (CFM)	310	310

Agency Certification

Empty enclosure is UL and UL-C approved. Enclosure meets all applicable European Union directives and is CE compliant. Final installed enclosures populated with your equipment should be inspected by your local UL/CSA committee, or other local safety governing organization if required. A complete listing of certifications is available from enclosure vendor. For installed Foxboro Evo equipment, refer to *Standard and Compact 200 Series I/O - Agency Certifications*, (PSS 31H-2CERTS).

Area Designation

Vented for general purpose environments.

Table 3. Fan Tray Specifications

Specification	115 V ac	230 V ac
Number of fans	3	3
Nominal Voltage(60 Hz)	115 V ac	230 V ac
Input Power	45 W	45 W

(1) Under normal operating conditions, with both fans and fan trays running, at enclosure's mid-height at 46 dB (A) ambient noise level.

PHYSICAL SPECIFICATIONS

Weight

The weight of the enclosure is dependent upon the particular configuration. Consult with a Foxboro representative if precise weight figures are required.

VENTED ENCLOSURE WITH SIDE PANELS
(ALLOWABLE MAX. WEIGHT WHEN LOADED)
800 x 800 mm (31.5 x 31.5 in) - 291 kg (642 lb)

Mounting

Floor

CAUTION

To prevent injury, this enclosure must be bolted down. Refer to *K-Series Enclosures Site Planning and Installation User's Guide* (B0700GN).

Construction

Sheet steel with textured, powder-coated finish

Color

SIDE PANELS, ROOF, AND DOORS

RAL 7035 - light gray - textured

PLINTH

RAL 7022 - umbra gray smooth

Panel Thickness

DOORS

1.8 mm (15 ga)

SIDE PANELS, ROOF

1.5 mm (16 ga)

Construction

MATERIAL

Doors

Sheet steel, 1.8 mm (15 ga)

Frame, Roof, Side Panels, Gland Plates

Sheet steel, 1.5 mm (16 ga)

Base/Plinth

Sheet steel and plastic

Construction (Cont.)

FINISH

Frame

Epoxy-polyester resin paint, textured RAL 7035 gray

Doors, Roof, Side Panels

Epoxy-polyester resin paint, textured RAL 7035 gray

Base/Plinth

Epoxy-polyester resin paint, textured RAL 7035 gray

Gland Plates and Internal Hardware

Zinc-plated, passivated

Cable Entry

Bottom through gland plate(s)

Earthing (Grounding)

ROOF, SIDEWALLS, GLAND PLATES

Automatic potential equalization built in

DOORS

Dedicated 6 mm² (10 ga) ground strap to enclosure frame

ENCLOSURE

Two M8 size studs (one for each enclosure side)
An isolated bus bar for additional earth (ground) points.

Power Input Terminals

TYPE

Ring Lug

WIRE SIZE

Up to 6 mm² (10 AWG)

RING LUG SIZE

M4 Maximum (DIN 46 234/46 237), 9.6 mm maximum O.D.

Termination Assembly Cabling

Universal mounting straps are supplied for securing, routing and strain relieving of termination assembly cables. Each strap supports up to a 75 mm (3 in) diameter cable bundle.

RELATED PRODUCT DOCUMENTS

Table 4. Reference Documents

Document Number	Description
B0700GN	K-Series Enclosures Site Planning and Installation User's Guide
PSS 31H-2C200	Compact 200 Series 16-Slot Horizontal Baseplate
PSS 31H-2SBASPLT	Standard 200 Series Baseplates
PSS 31H-2C480 B4	Compact Power Supply - FPS480-24
PSS 31H-2CERTS	Standard and Compact 200 Series I/O - Agency Certifications
PSS 31H-2COV	Compact 200 Series I/O Subsystem Overview
PSS 31H-2KOV	K-Series Enclosures Overview
PSS 31H-2K13	K13 System Enclosure
ISA-S71.04-1985 (not Foxboro-supplied)	Environmental Conditions for Process Measurement and Control Systems: Airborne Contaminants

DIMENSIONS - NOMINAL

K14 System and Termination Enclosure

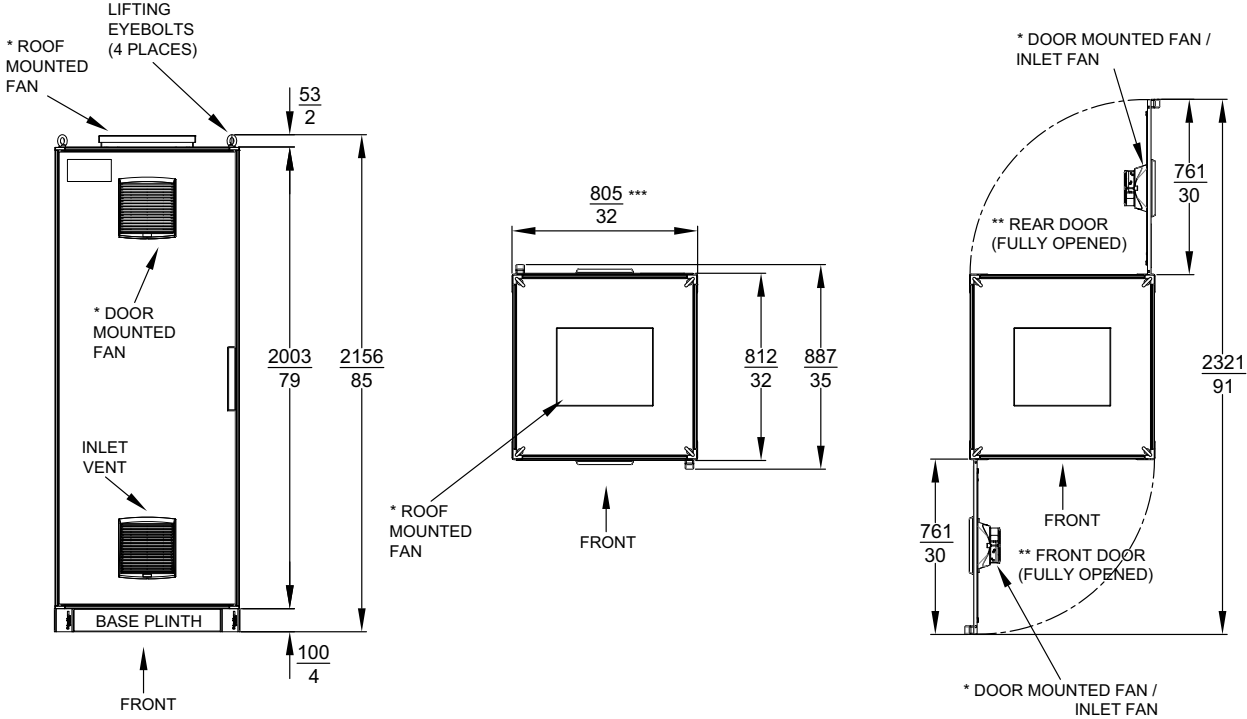

* VENTED ENCLOSURES ONLY- EITHER ROOF- OR DOOR MOUNTED CONFIGURATIONS CAN BE ORDERED.
** DOORS ARE FACTORY CONFIGURED FOR LEFT-HAND SWING, BUT CAN BE RECONFIGURED AT SITE FOR RIGHT-HAND SWING.
*** WITH / WITHOUT SIDE PANELS.



Invensys Systems, Inc
10900 Equity Drive
Houston, TX 77041
United States of America
<http://www.invensys.com>

Global Customer Support
Inside U.S.: 1-866-746-6477
Outside U.S.: 1-508-549-2424
Website: <https://support.ips.invensys.com>

Copyright 2015 Invensys Systems, Inc.
All rights reserved.
Invensys is now part of Schneider Electric.

Schneider Electric, Invensys, Foxboro, and Foxboro Evo are trademarks owned by Schneider Electric SE, its subsidiaries and affiliates.
All other trademarks are the property of their respective owners.

MB 031

0815