

# Foxboro Evo™ Process Automation System

## Product Specifications

# Foxboro®

by Schneider Electric

PSS 31H-2K50

## K50 Server Enclosure



*The Foxboro Evo™ K50 Server Enclosure with front and rear access provides environmental protection and housing for compatible Foxboro Evo workstations, servers and the Foxboro Evo Control Network switches.*

### OVERVIEW

The Foxboro Evo K50 server enclosure is a general purpose unit designed for housing compatible servers, Ethernet switches, and related equipment on shelves or on its 19-inch racks. The K50 enclosure is available as a vented enclosure only.

The enclosure's rails provide 42 U of available vertical mounting space for rack-mounted or other equipment. The upper and lower halves of the enclosure are customizable, and may be either left empty or populated with various equipment configurations:

- ▶ Up to two sliding shelves; shelves can support the Windows® based tower workstations, such as the Model H92 workstation, depending on the size and ventilation requirements of the equipment.

### NOTE

It is recommended that when using sliding shelves, only one shelf is pulled out at a time to prevent the enclosure from becoming unbalanced.

- ▶ Equipment secured directly to the rails, such as the control network switches - depending on the sizing, power, cabling and ventilation requirements of the equipment.

**NOTE**

Typically, workstations and servers are installed for access from the enclosure front, while switches are installed for access from the enclosure rear.

The K50 enclosure is a free-standing, floor mounted unit with an NEMA 1<sup>(1)</sup> rating for location in protected indoor environmental areas. No fans are provided with this enclosure as all enclosed equipment (servers, switches, and so forth) are assumed to have their own fans.

**FEATURES**

The K50 server enclosure with front and rear access offers the following features:

- ▶ 600w x 1000d x 2000h mm high enclosure, available as vented only
- ▶ Front and rear accessible 19-inch system rails, with 42 U of available vertical mounting space (1U = 44mm (1.75 in))
- ▶ Enclosure front access with left- or right-side mounted door - rear access with half-width doors
- ▶ Main power entry includes 15 A, Type D, double pole circuit breakers for 120/240 V ac systems.
- ▶ Enclosure selection for use in indoor NEMA 1 rated (not IP rated) temperature-controlled environments

- ▶ Enclosure can accommodate:

- Up to two sliding shelves per enclosure for Model H92 workstations; each shelf with up to two pairs of power strips (15A max/10A per socket)

**NOTE**

A rail mounting kit is included with the Model H90 servers for mounting in this enclosure.

A fixed rail rack kit is available to mount Model H92 (HP Z400, HP Z420, and HP Z440) workstations in this enclosure.

- Rack-mounted equipment secured directly to the 19-inch rails, such as the control network switches, depending on sizing, power, cabling and ventilation requirements.

- ▶ Compact design to minimize use of floor space with both front and rear access that allow maximum density of enclosures in a control room environment
- ▶ Bottom or top cable entry for power wiring, but can be customer configured for simultaneous top and bottom cable entry
- ▶ Up to four redundant power strips (four primary and four secondary) per enclosure (eight total)
- ▶ Conveniently placed eyebolts for transporting and lifting the enclosures
- ▶ A 100 mm (3.9 in) plinth - total enclosure height of 2160 mm (85.0 in)
- ▶ Comfort handles with push-button or keylocks
- ▶ Standard safety earthing (grounding) studs.

(1) The K50 enclosure does not have an IP rating as air flow is allowed through ceiling, floor and all walls.

## SAMPLE CONFIGURATIONS

The K50 enclosure can fit a variety of workstations, servers, switches, and their associated power supplies and support equipment.

### NOTE

All switches must be installed in the K50 enclosure with the site requirements listed in their documentation. Refer to “SITE PLANNING FOR SWITCHES” on page 9 to locate the appropriate documentation.

### NOTE

Power strips are mounted on front or rear side of the enclosure based on the configuration.

## BAYING K50 ENCLOSURES

Multiple K50 enclosures can be installed connected to one another to optimize the use of floor space. The enclosures can be bayed together using baying kits, discussed in the *K-Series Enclosures Site Planning and Installation User's Guide* (B0700GN).

## NATIONAL ELECTRICAL MANUFACTURERS ASSOCIATION RATING

The metal enclosures provide the outer layer of protection for the equipment contained within to support a NEMA 1 rating. When the equipment includes covers or layers built into the equipment itself, a minimum of contaminants in the plant environment reaches the equipment, thus greatly extending its life.

The enclosures support convenient top or bottom cable entry for power wiring.

## EQUIPMENT MOUNTING

All equipment installed in this enclosure must be attached to the 19-inch rails directly or indirectly via a sliding shelf. As well, all equipment must be able to fit within the physical constraints of the enclosure with sufficient space for air flow and associated cabling, including cable routes, sufficient bend radius and

dressing.

All servers, switches and similar equipment which require air intake must be installed to maintain a consistent air flow in a single direction in the enclosure. The air intakes for these equipment must face the same direction, and their exhausts must face the same direction to ensure that no hot exhaust from one piece of equipment enters in the air intake of another.

### NOTE

Ensure that the front and rear doors on the enclosure allow for unrestricted air flow, and are not obstructed by objects such as print pockets.

## INPUT POWER CABLING

The enclosures can be configured for bottom cable entry or top cable entry or modified by the customer for simultaneous top and bottom cable entry.

For the top cable entry version, customer power feeds enter through customer-configured cable glands.

For the bottom entry version, the power cables enter through removable gland plates, located at the bottom (inside) of the enclosure, which can be removed, drilled, or punched for cable routing.

## POWER AND EARTHING (GROUNDING)

Power wiring to the enclosure is routed through the bottom (through removable gland plates) or top of the enclosure. Customer-supplied dual power input feeds terminate at circuit breaker assemblies.

All enclosure structural elements are integrally earthed by the enclosure design to meet the appropriate industry regulations and standards.

### Earthing (Grounding)

Two M8 studs (one for each enclosure side) provide a central earth (ground) point and dedicated earthing points when baying enclosures together.

### Power Distribution

Each enclosure is available with a dedicated assembly for customer redundant main power. Power distribution is provided by 15 A, Type D, double pole circuit breakers for 120/240 V ac systems.

The enclosure may be ordered without these power distribution circuit breakers when the customer has requirements for power distribution specific to regional electrical codes.

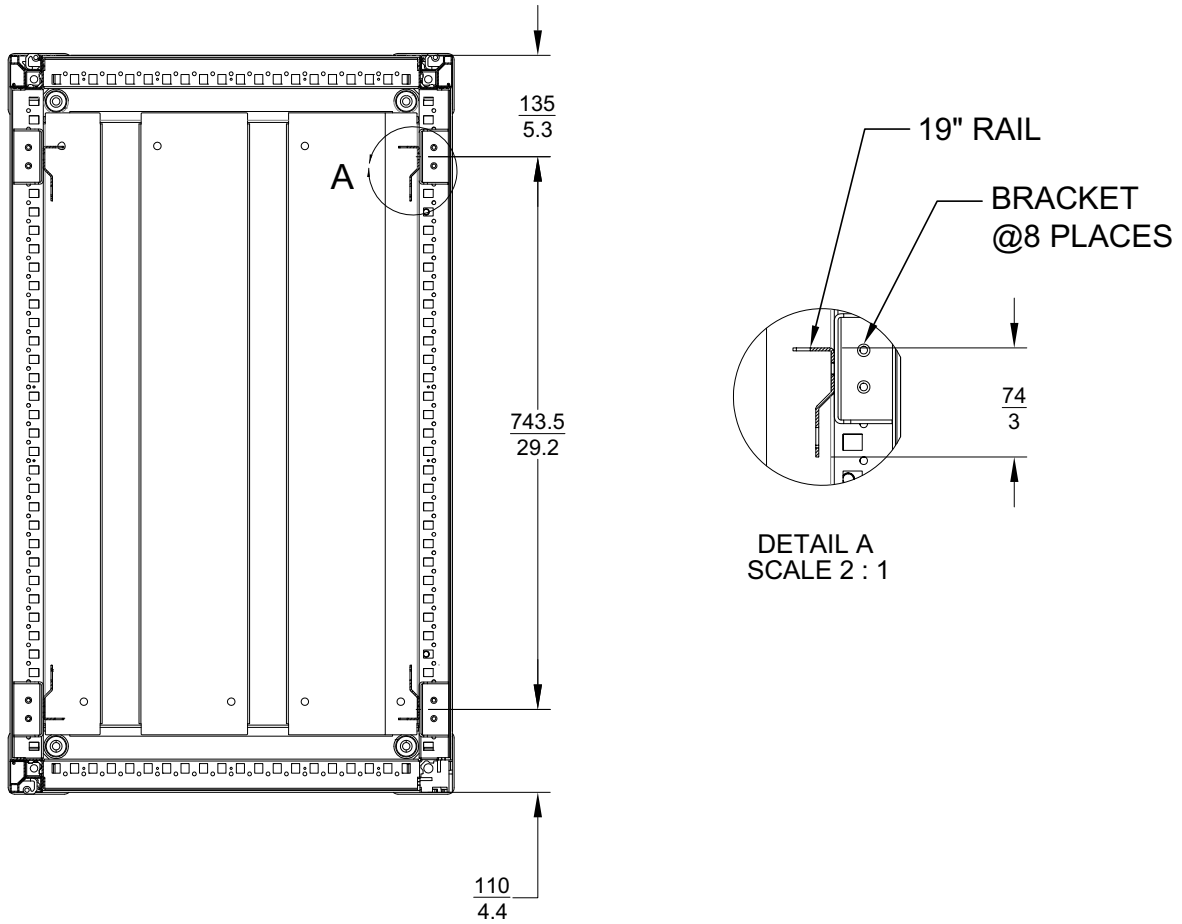

Figure 1. K50 Server Enclosure - Top View - Rails



Figure 2. K50 Server Enclosure, Empty, Bottom Entry, Front View



Figure 3. K50 Server Enclosure, Empty, Bottom Entry, Rear View



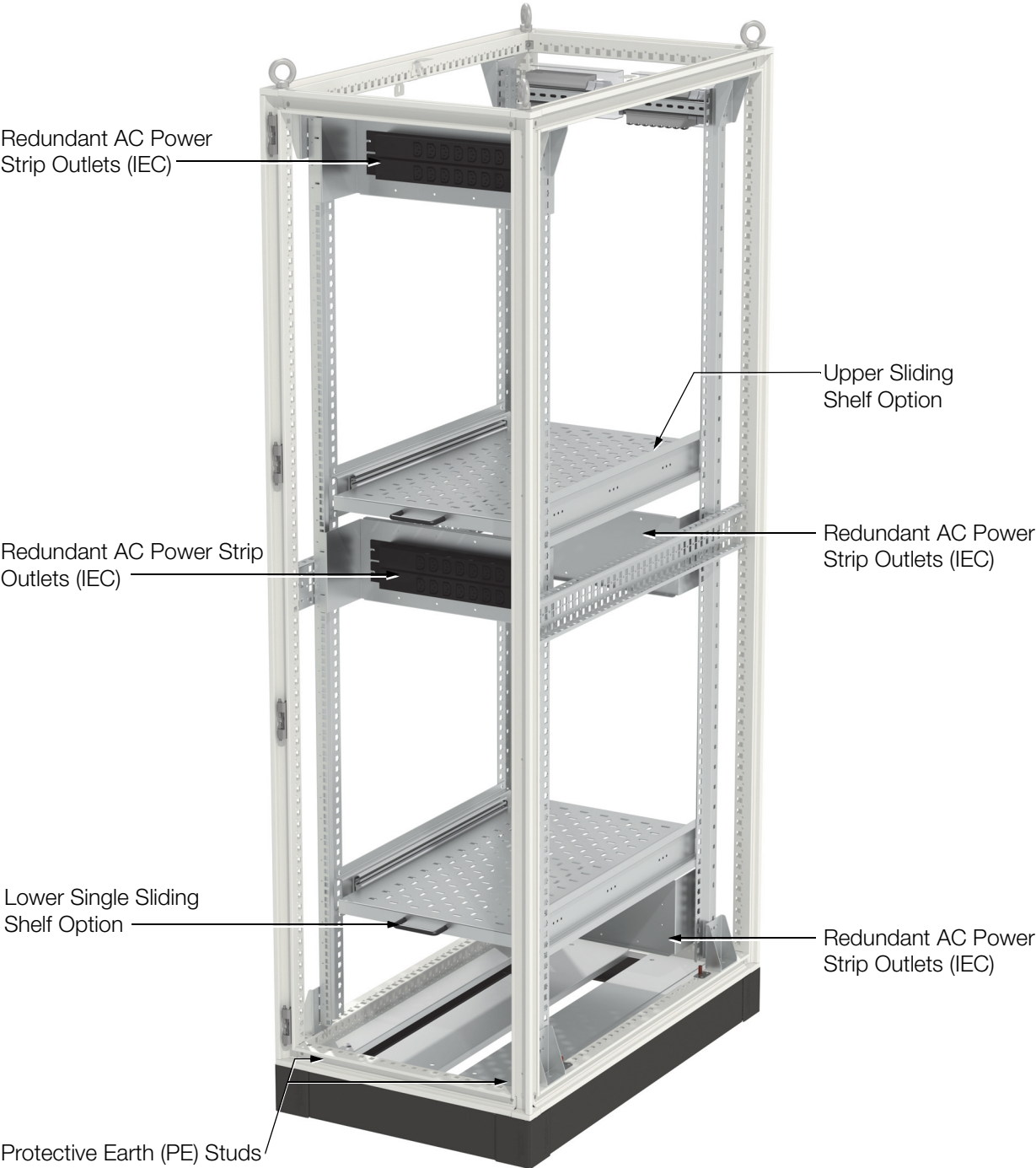
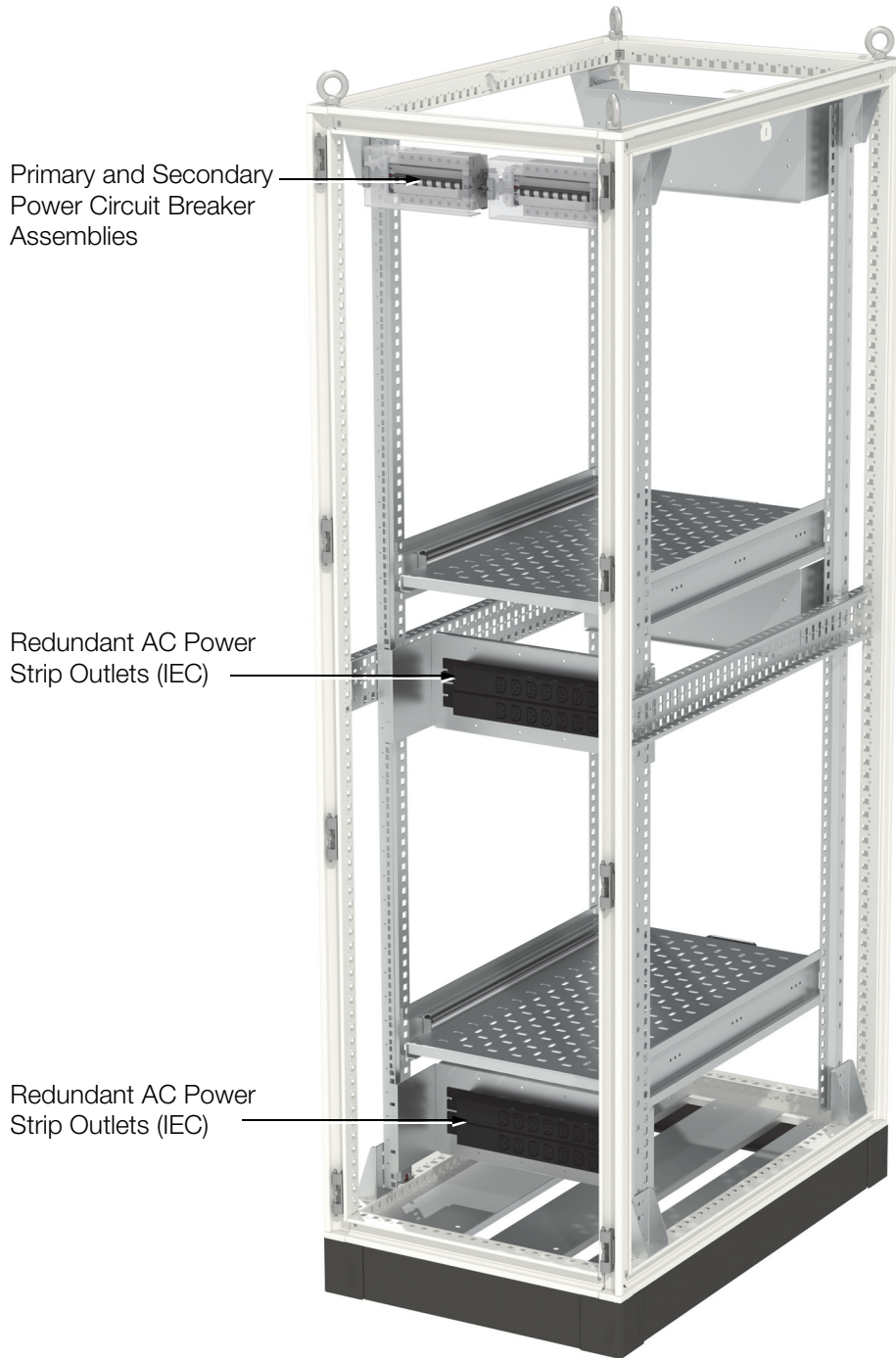

Figure 4. K50 Server Enclosure, Empty, Top Entry, Front View



*Figure 5. K50 Server Enclosure, Empty, Top Entry, Rear View*



## SITE PLANNING FOR SWITCHES

When planning a K50 enclosure with switches installed, you must ensure that the site requirements for the switches are maintained within the enclosures. These site requirements are in the documentation provided by Foxboro®.

Refer to the following Foxboro documentation for the switches, workstations, and servers currently offered<sup>(2)</sup>. Refer to:

- ▶ *The Foxboro Evo Control Network Ethernet Equipment* (PSS 31H-7NW\_EQUIP) for the complete list of switches and their associated Foxboro documentation.
- ▶ *Model H90 Workstation Server for Windows Server 2008 R2 Operating System* (PSS 31H-4H90) for the H90 server.
- ▶ *Model H92 Workstations Windows 7 Professional Operating System* (PSS 31H-4D13) for the H92 workstation.

---

<sup>(2)</sup> This list is subject to change. Refer to *The Foxboro Evo Control Network Ethernet Equipment* (PSS 31H-7NW\_EQUIP) for the most up-to-date list of switches offered.

**ENCLOSURE FEATURES AND OPTIONS**

The K50 enclosure is provided with the following features, some of which are optional.

**Table 1. K50 Enclosure Features and Options**

Feature	Availability
Base Enclosure	Vented NEMA 1 rated (not IP rated) enclosure (no fans)
Enclosure Access	Front and rear access
Front Door	Perforated single door
Front Door Mounting	Universal mounting for left or right-hand door swing (left-hand is default)
Rear Door	Perforated half-width doors
Cable Entry	Bottom cable entry or top cable entry
Sidewalls	Options configurable based on buying requirements
Door Handle	Handle with push-button or keylocks
Equipment Supported (In Upper or Lower Half of Enclosure)	Rack-mounted equipment secured directly to the rails (no support provided) Up to two sliding shelves.
Power Cord Sets (In Upper or Lower Half of Enclosure)	Two, four, six or eight IEC-320 male/female cord sets
Enclosure Lighting	None
Earthing (Grounding)	Two protective earth (ground) studs
Main Power	100-250 V ac, 50-60Hz input redundant power with 15 A, Type D, double pole circuit breakers, located in either the top or bottom of the enclosure Additionally, customer configured power entry (no provision for powering devices)

## FUNCTIONAL SPECIFICATIONS

### Enclosure

The enclosures are free-standing, floor mounted, steel industrial enclosures containing 19" rack and shelf-mounted compatible servers, the control network switches, and related equipment, as discussed in this document.

## ENVIRONMENTAL SPECIFICATIONS

### National Electrical Manufacturers Association Ratings

Not IP rated/NEMA 1

### Operating Temperatures

Dependent on equipment loaded in the enclosure. Refer to the specifications listed in the equipment's Product Specification Sheet or other documentation.

#### **THERMAL WATTAGE LIMITS (FOR NON-ADJOINED ENCLOSURES)<sup>(3)</sup>**

Dissipation of 1000 W generates a +5°C (9°F) heat rise

### Storage Temperature

-40 to 70°C (-40 to 158°F)

### Relative Humidity

5 to 95% (noncondensing)

### Acoustic Noise Level

Ambient

### Agency Certification

Empty enclosure is UL and UL-C approved. Enclosure meets all applicable European Union directives and is CE compliant and RoHS compliant. Final installed enclosures populated with your equipment should be inspected by your local UL/CSA committee, or other local safety governing organization if required.

A complete listing of certifications is available from enclosure vendor. For installed Foxboro Evo equipment, refer to PSS 31H-2CERTS.

### Area Designation

Vented for general purpose areas.

---

<sup>(3)</sup> The effective heat rise should be added to the planned ambient temperature and the result should be lower than the rated maximum ambient temperature of the equipment to be installed.

## PHYSICAL SPECIFICATIONS

### Weight

The weight of the enclosure is dependent upon the particular configuration and equipment selected. Consult with a Foxboro representative if precise weight figures are required.

#### ENCLOSURE (MAX. CONFIGURATION)

600 mm wide x 1000 mm deep - 253 kg (558 lb)

#### SIDE PANEL

2000 mm high x 1000 mm deep - 19 kg (42 lb)

### Mounting

Floor

#### CAUTION

To prevent injury, this enclosure must be bolted down. Refer to the installation guide.

### Construction

#### MATERIAL

##### *Doors*

Sheet steel, 1.8 mm (15 ga)

##### *Frame, Roof, Side Panels, Gland Plates*

Sheet steel, 1.5 mm (16 ga)

##### *Base/Plinth*

Sheet steel and plastic

#### FINISH

##### *Frame*

Epoxy-polyester resin paint, textured RAL 7035 gray

##### *Doors, Roof, Side Panels*

Epoxy-polyester resin paint, textured RAL 7035 gray

##### *Base/Plinth*

Epoxy-polyester resin paint, textured RAL 7035 gray

##### *Gland Plates and Internal Hardware*

Zinc-plated, passivated

### Weight Load Supported Per Telescoping Shelf

100 kg (220 lb) (maximum)

### Cable Entry

Bottom through gland plate(s)

Top through customer cutouts in enclosure top

### Earthing (Grounding)

#### ROOF, SIDEWALLS, GLAND PLATES

Automatic potential equalization built in

#### FRONT AND REAR DOORS

Dedicated 6 mm<sup>2</sup> (10 ga) ground strap to enclosure frame

#### ENCLOSURE

Two protective earth (ground) M8 studs (one for each enclosure side)

### Power Input Terminals

#### CIRCUIT BREAKERS (15AMP EACH)

##### *Type*

Compression

##### *Wire Size*

Solid: Up to 6 mm<sup>2</sup> (3 AWG)

Stranded: Up to 4 mm<sup>2</sup> (8 AWG)

### Enclosure Equipment Cabling

Universal mounting straps are supplied for securing, routing and strain relieving of enclosure equipment cables. Each strap supports up to a 75 mm (3 in) diameter cable bundle.

DIMENSIONS - NOMINAL

K50 Server Enclosure

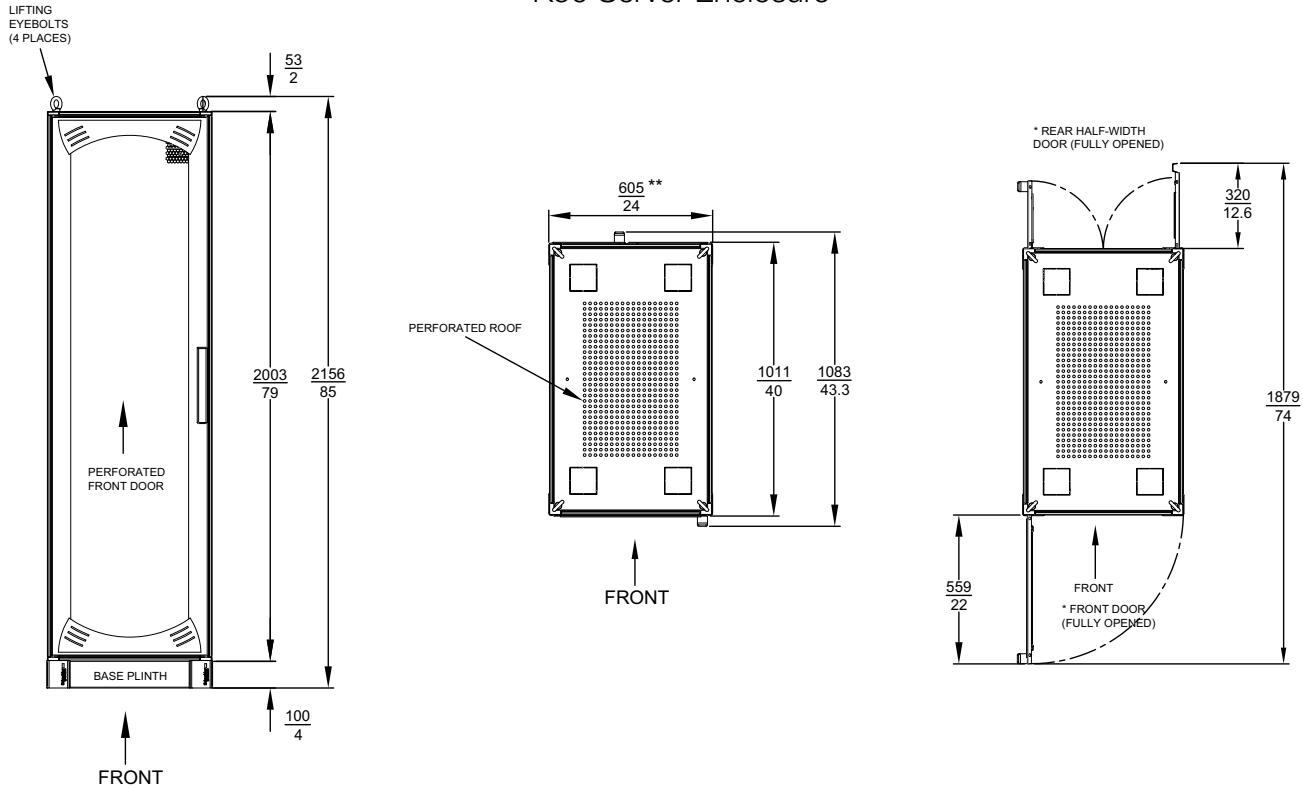

\* DOORS ARE FACTORY CONFIGURED FOR LEFT-HAND SWING, BUT CAN BE RECONFIGURED AT SITE FOR RIGHT-HAND SWING.  
 \*\* WITH / WITHOUT SIDE PANELS.

**FOR MORE INFORMATION**

For additional information describing Foxboro Evo enclosures with 200 Series I/O subsystem equipment, refer to the following documentation:

Document Number	Description
PSS 31H-2KOV	K-Series Enclosures Overview
PSS 31H-4H90	Model H90 Workstation Server for Windows Server 2008 R2 Operating System
PSS 31H-4D13	Model H92 Workstations Windows 7 Professional Operating System
PSS 31H-7NwEquip	The Foxboro Evo Control Network Ethernet Equipment
B0700CE	The MESH Control Network Hardware Instructions for S-Series Switches (P0973KD/P0973KK/P0973LN)
B0700CF	A4-Series (P0973JM/P0973JN/P0973JP) Switches, Hardware and Software Configuration Instructions
B0700CJ	The Foxboro Evo Control Network Hardware Instructions for C-Series Switches (P0973KJ/HA/BL) and B-Series Switches (P0973LK)
B0700CN	I-Series (P0973GA/GB/HB/HC) Industrial Switch, Hardware and Software Configuration Instructions
ISA-S71.04-1985 (not Foxboro-supplied)	Environmental Conditions for Process Measurement and Control Systems: Airborne Contaminants







Invensys Systems, Inc  
10900 Equity Drive  
Houston, TX 77041  
United States of America  
<http://www.invensys.com>

Global Customer Support  
Inside U.S.: 1-866-746-6477  
Outside U.S.: 1-508-549-2424  
Website: <https://support.ips.invensys.com>

Copyright 2015 Invensys Systems, Inc.  
All rights reserved.  
Invensys is now part of Schneider Electric.

Schneider Electric, Invensys, Foxboro, and Foxboro Evo are trademarks owned by Schneider Electric SE, its subsidiaries and affiliates.  
All other trademarks are the property of their respective owners.

MB 031

0815