

Remote Terminal Unit (RTU)

SCD2200 for Oil, Gas, and Water SCADA Applications



NOTE

This is a representative image only.

The Foxboro® SCD2200 is an Intelligent Station Computing Device capable of performing a full range of control and data acquisition functions in all industrial remote SCADA applications.

SCD2200 OVERVIEW

The SCD2200 is designed to operate remotely in harsh environments and can be easily configured for SCADA applications such as:

- ▶ Oil and gas production including offshore platforms
- ▶ Well monitoring, wet gas, and high level well control applications
- ▶ Oil and gas transportation facilities including pipelines
- ▶ Water and wastewater treatment plants
- ▶ Water and heating distribution networks

To match the customer needs, the SCD2200 supports several modular plug-and-play options.

For example, low-density or high-density I/O modules, redundant CPU, redundant power supplies, power-integrated backplanes, communication lines, interfaces to the typical communications media, and optimized transmission techniques for low speed data lines are available.

Based on a 166 MHz high performance CPU and extensive flash memory, the SCD2200 performs a wide range of control functions, from simple data acquisition to sophisticated closed-loop algorithms

through a user-friendly sequence configurator (graphic and literal programming languages compliant to IEC 61131-3 & IEC 61499).

The SCD2200 is highly scalable with both powered (BP-x) and non-powered (BPLN) backplanes. The smallest SCD2200 configuration is available in a compact 2-slot integrated-power backplane (BP-2). Unlike BPLN backplanes, powered backplanes do not need a power supply (PS-x) module. Therefore, the BP-x backplanes provide full capacity, that is, all their slots can be utilized for other modules. BPLN backplanes are available in the 4, 6, or 12-slot variations and BP-x backplanes are available in the 2, 4, or 6-slot variations.

SCD2200 can support the 2-slot, 4-slot, 6-slot, or 12-slot variations of these backplanes. The 12-slot (BPLN) backplane configuration can be further expanded into racks to a maximum of 64-slots (modules) per logical node. These SCD2200 configurations are suitable for indoor mounting or outdoor field mounting when installed within an IP65/NEMA4 certified enclosure supplied by third party vendors.

FEATURES

Key features include:

- ▶ Low power consumption
- ▶ High reliability, modularity, and accuracy
- ▶ Redundancy of CPU (optional), power supply, and communication lines
- ▶ Flexible hardware configuration
- ▶ Easy plug and play installation
- ▶ Default-configuration at power on
- ▶ IEC 61131-3 compliant user-friendly sequence configurator for RTU-resident automatic sequence and control functions
- ▶ 32-bit CPU, operating at 166 MHz
- ▶ 64 MB RAM with 16 MB FLASH memory (default 9 MB free)
- ▶ Up to 5 dual communications modules, high I/O density cards
- ▶ Power supply modules with built-in battery backup charger, with battery temperature feedback
- ▶ 1,500 VRMS isolation for all I/O channels
- ▶ DNP3 Master and Slave
- ▶ DNP3 Secure Authentication 2.0
- ▶ Modbus Master and Slave
- ▶ Secure Authentication (Role Based Access Control)
- ▶ Terminal Server
- ▶ Integrated-power backplanes
- ▶ Combined Digital/Analog IO modules
- ▶ P6008 Protocol (Slave only)
- ▶ Enhanced event logging and handling with storage and retrieval capacity of 100,000 events
- ▶ Efficient DNP3 event reporting mechanism to support up to 4 DNP3 Masters
- ▶ Supports Web Server to monitor RTU diagnostic information.

SCD2200 TYPICAL FUNCTIONS AND FUNCTIONAL PROGRAMMING ENVIRONMENT

Typical functions of the SCD2200 include:

- ▶ Pulse inputs acquisition, counting, and freezing
- ▶ Pulse or permanent digital outputs
- ▶ Digital and analog outputs with check-before-operate security
- ▶ Programmable Sequence Control functions through user-friendly package
- ▶ I/O signals driven by local sequences

- ▶ Sequence-programs allowing remote loading/unloading
- ▶ Store and forward communication technique for time stamped digital/analog chronological archives
- ▶ Report by Exception scanning
- ▶ Broadcast addressing, protocol dependent
- ▶ Dial-up, unsolicited, and spontaneous calls from RTU to control centers on switched telephone lines
- ▶ Interface to a local operator workstation or diagnostic terminal
- ▶ Sequence of Events (SOE) with 1 ms resolution
- ▶ Powerful RTU and/or PLC using local and remote

I/O (optional)

- ▶ Flow calculation (optional): AGA3, AGA7, AGA8, NX19
- ▶ Management of PID algorithms

FoxRTU Station Software

The FoxRTU Station software is an integrated operating environment that combines configuration, programming, development, and maintenance in one simple-to-use package. You can view, edit, and diagnose your SCD2200 solution with a single, highly intuitive user interface.

Figure 1 shows the status of modules in the RTU slots using FoxRTU Station.

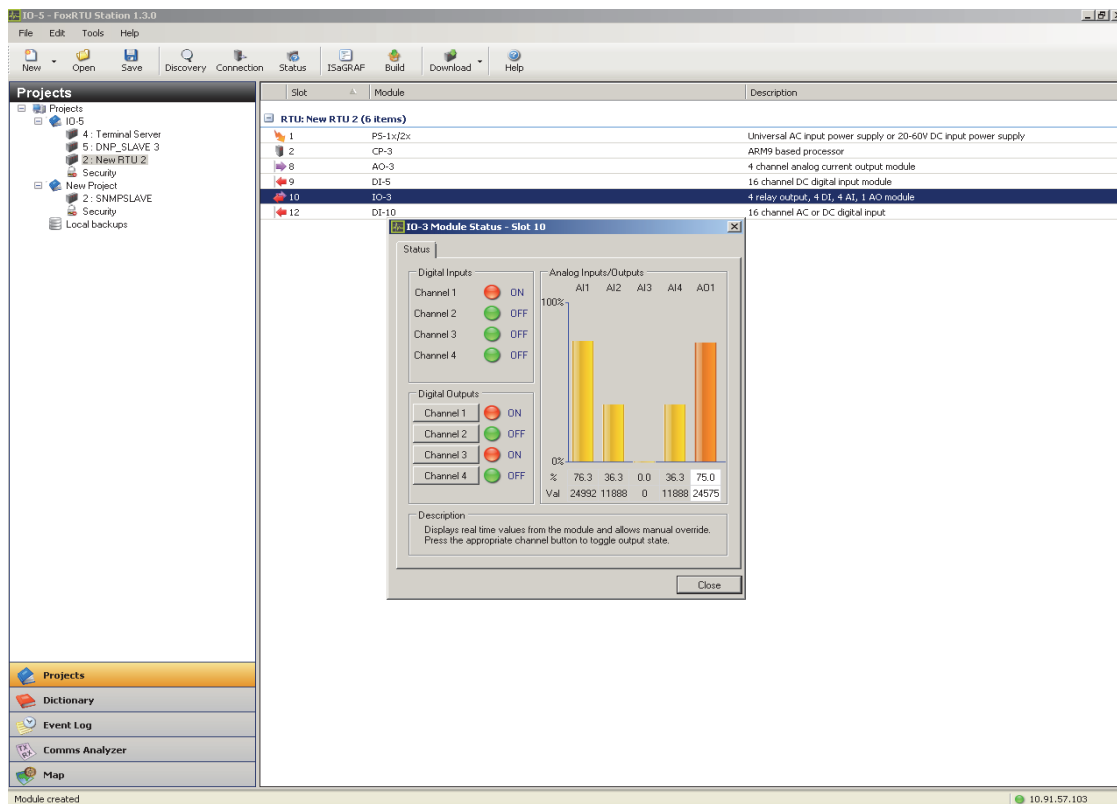

Figure 1. Functional Engineering Environment (FoxRTU Station)

The Security function implemented in the FoxRTU Station, provides a role-based access control to restrict the availability of system features only to authorized users. FoxRTU Station eliminates the need to change back and forth between software packages or engage in complicated programming as you move from module to module.

With its embedded IEC-61131-3 compliant standard, the system supports:

- ▶ Ladder Logic
- ▶ Structured Text
- ▶ Function Block Diagrams
- ▶ Sequential Function Charts
- ▶ Instruction Lists
- ▶ Flowcharts

In addition, pre-programmed function blocks make it easy to add new capabilities to your SCD2200 RTU solution.

ARCHITECTURE

The SCD2200 architecture is based on a bus structure sharing all RTU functional blocks: CPU, I/O modules, and communication modules supporting communication line interfaces.

You can easily install or remove each I/O module through standard DIN 41612 connectors. All modules are equipped with front-mounted diagnostic and indication LEDs. The modules are hot swappable, but are capable of being configured in a redundant configuration on the serial backplane.

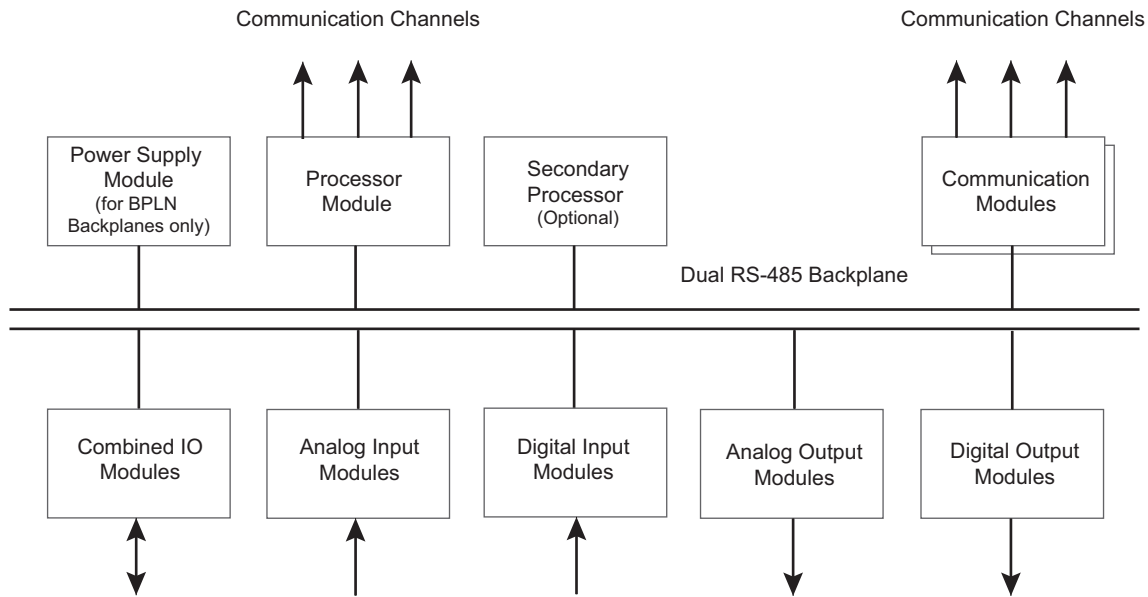

Figure 2. SCD2200 Bus Architecture

HARDWARE LAYOUT

The SCD2200 is a modular computing device that uses a system of similar modules, which plug into a backplane. There are two types of backplanes.

- ▶ Passive (BPLN) backplanes are powered by Power Supply (PS-xx) modules that need an external AC or DC power supply.
- ▶ Integrated-power (BP-x) backplanes are powered externally by a 12 V/5 A DC power supply and do not need a PS-xx power supply.

BPLN backplanes are available in the 4, 6, or 12-slot variations and BP-x backplanes are available in the 2, 4, or 6-slot variations. You can combine multiple backplanes with extender cables to form a larger RTU. However, you can include only one BP-x backplane (configurable only in the first rack) per RTU. See Figure 8, Figure 9, Figure 11, and Figure 12.

Each rack mounted system that uses BPLN/BP-x backplanes can operate with either a single CPU (CP-3 module) or dual CPUs in redundant mode. A common arrangement for redundancy is to manage a non-redundant set of I/O modules with:

- ▶ Two CPUs for BP-x backplanes
- ▶ Two CPUs and two power supplies for BPLN backplanes

CP-3 MODULE

The 32-bit CPU consists of:

- ▶ 166 MHz clock speed
- ▶ Real-time calendar clock
- ▶ One Fixed Ethernet 10/100 Base T Port
- ▶ Two optional communication ports supporting a number of communication interface cards
- ▶ AT-HAYES compatible firmware protocol to drive the modem and the external radio devices

- ▶ Field replaceable internal lithium battery for easier maintenance.
- ▶ Factory Reset option, on the front of the panel, allows easy and quick reset without removing the panel even when it is powered up/running. For more information, refer
- ▶ Upgraded SRAM to 512 KB and SDRAM to 64 MB

The CP-3 module supports both MC-3 and MC-31 modules in a mixed communications environment.

Refer to *SCD2200 Hardware User's Guide* (B0780AE) for more details.



Figure 3. SCD2200 CP-3 CPU Module

MC-31 OPTIONAL COMMUNICATION MODULE

The MC-31 communication module is an optional module, which supports many communication line interfaces. The MC-31 communication module contains a fixed Ethernet communication port and two optional communication ports supporting a number of communication interface cards.

These optional communication cards include:

- ▶ OPT D: V.34 PSTN Dial
- ▶ OPT F: Serial over optical
- ▶ OPT H: Hart Bell 202-1 to 15 devices multi-drop
- ▶ OPT I: Isolated serial [RS-232, RS-485, RS-422]
- ▶ OPT II: Isolated Dual channel Serial port-option board [RS-232, RS-485, RS-422]
- ▶ OPT L: V.23 2/4 wire for leased line and packet data radio interface support
- ▶ OPT R2: Spread Spectrum 900 MHz Australian version
- ▶ OPT R3: Spread Spectrum 2.4 GHz International version, available on Port 3
- ▶ OPT R4: Spread Spectrum 900 MHz US version
- ▶ OPT T3: 10/100BaseT Ethernet

The MC-31 communication module requires the CP-3 module as a pre-requisite module.



Figure 4. MC-31 Communication Module

INPUT/OUTPUT (I/O) MODULES

Common characteristics of I/O modules are:

- ▶ HCMOS technology
- ▶ Optical isolation
- ▶ Address free
- ▶ Front-mounted diagnostic LED and indication LED that allow quick disconnect I/O terminations

The available I/O modules are:

- ▶ Analog input modules (AI-10 and AI-10-V)
- ▶ Analog output modules (AO-3)
- ▶ Digital input modules (DI-5 and DI-10)
- ▶ Digital output modules (DO-1, DO-2, and DO-6)
- ▶ Combination Analog/Digital IO Modules (IO-3 and IO-5)



Figure 5. Typical SCD2200 I/O Modules

POWER SUPPLY MODULES

The available power supply modules are:

- ▶ PS-12 AC input, 100 to 240 V_{AC} power supply (without 24 V_{DC} isolated converter)
- ▶ PS-22 DC input, 20 to 60 V_{DC} power supply (without 24 V_{DC} isolated converter)
- ▶ PS-12 AC input, 100 to 240 V_{AC} power supply with 24 V_{DC} isolated converter
- ▶ PS-22 DC input, 20 to 60 V_{DC} power supply with 24 V_{DC} isolated converter

You can plug in or plug out the power supply modules while the RTU backplane is still ON. However, you must disconnect the input power supply (AC or DC) on the power supply module while plugging in or out from the backplane.

Power supply modules are required only for BPLN backplanes. They are not required for the BP-x backplanes.



Figure 6. SCD2200 Power Supply Module

BACKPLANES

The backplane hosts all the SCD2200 modules that make up an RTU. It allows the processor module to communicate with other modules within the same RTU. It also distributes power to each module. There are two types of backplanes:

- ▶ BPLN (passive) backplanes
- ▶ BP-x (integrated-power) backplanes

You can link multiple backplanes together to create an RTU with up to 64 modules.

Backplanes are designed for surface mounting to support all of the modules and supplied with individual mounting brackets.

You can use a special 19-inch rack backplane mounting bracket to mount any of the following backplane combinations in a 19-inch rack.

- ▶ One 2-slot backplane and one 4-slot backplane
- ▶ One or two 4-slot backplanes
- ▶ One 6-slot backplane

You can use a set of alternative WINGS rack mounting brackets to mount a 12-slot backplane in a 19-inch rack.

Passive Backplanes

A BPLN backplane powers its modules using a Power Supply (PS-xx) module that is connected to an external AC or DC supply. Therefore, you must install a PS-xx module in one of its slots to run the RTU.

These backplanes provide a flexible solution for creating medium- to large-scale RTUs of any desired configuration. The available variants are:

- ▶ 4 BPLN (4-slot backplane)
- ▶ 6 BPLN (6-slot backplane)
- ▶ 12 BPLN (12-slot backplane)

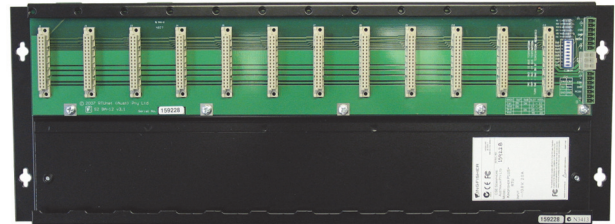

Figure 7. Empty 12-Slot Backplane

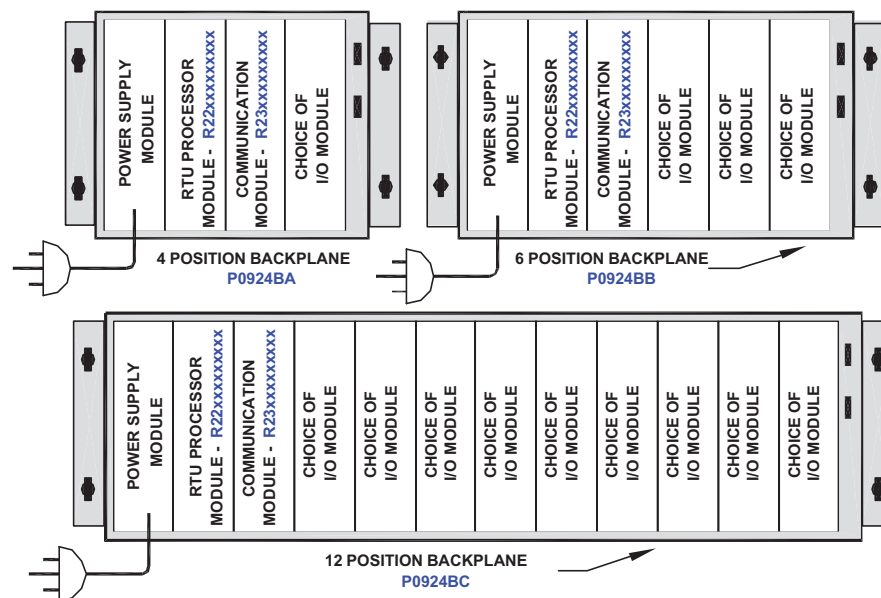

Figure 8. BPLN Backplane Module Layouts

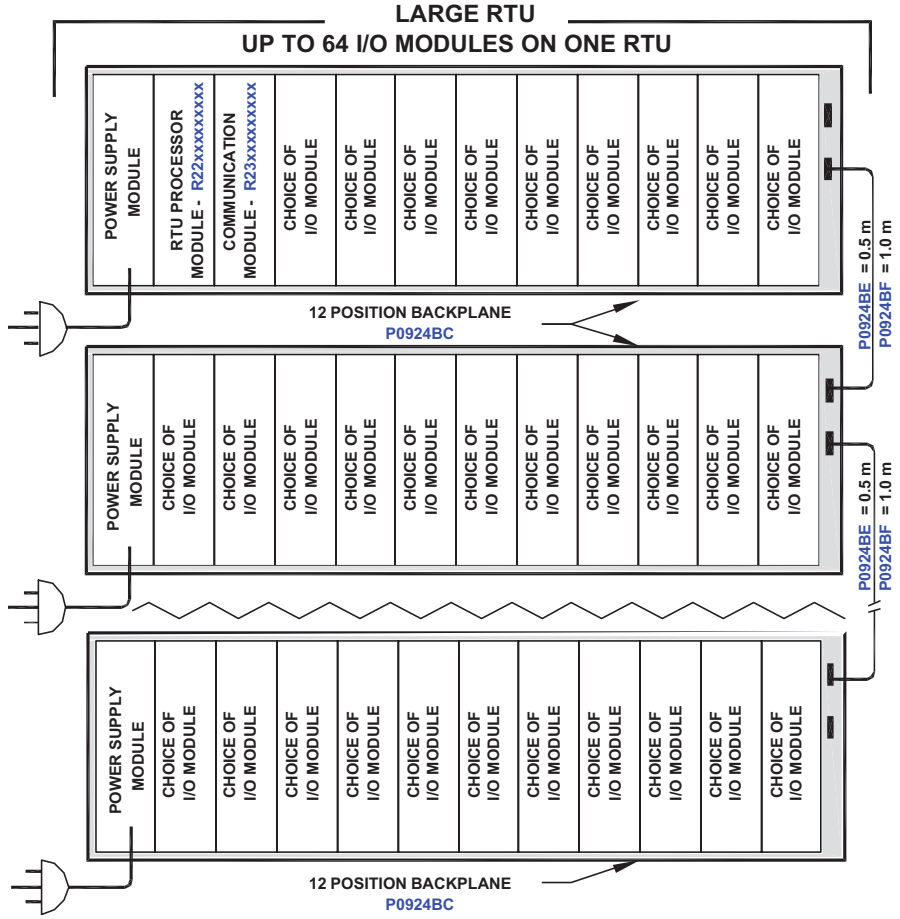

Figure 9. Large RTU with BPLN Backplanes

Integrated-power Backplanes

Though the BP-x backplanes serve the same purpose as the BPLN backplanes, they do not require a PS-xx module to power the other connected modules. These backplanes have an integrated 5 V power supply and require only an external 12 V DC power source. They have a switchable auxiliary 12 V output to power extra circuits and indicate the status of the power rail. These backplanes have limited expansion and configuration capabilities and are mainly aimed at small-scale, low-cost RTUs. The available variants with integrated 5 V power supply are:

- ▶ BP-2 (2-slot backplane)
- ▶ BP-4 (4-slot backplane)
- ▶ BP-6 (6-slot backplane)

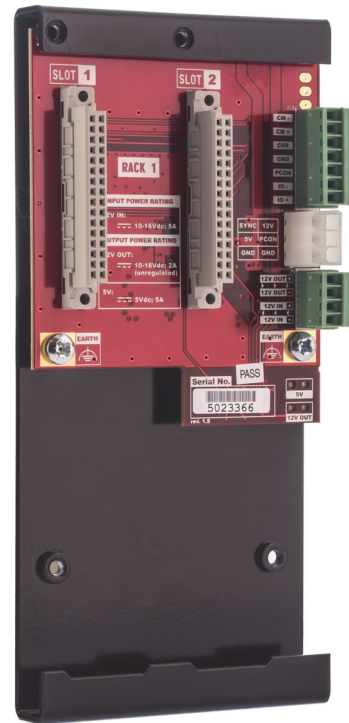

Figure 10. Empty 2-Slot Backplane

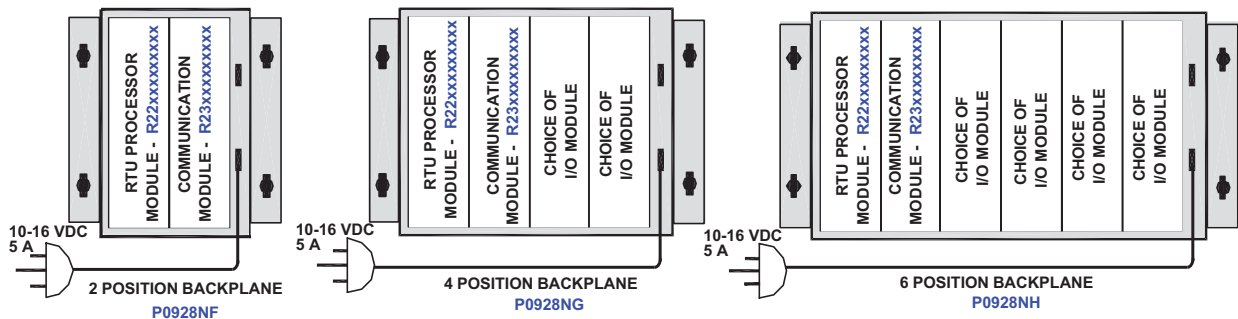

Figure 11. BP-x Backplane Module Layouts

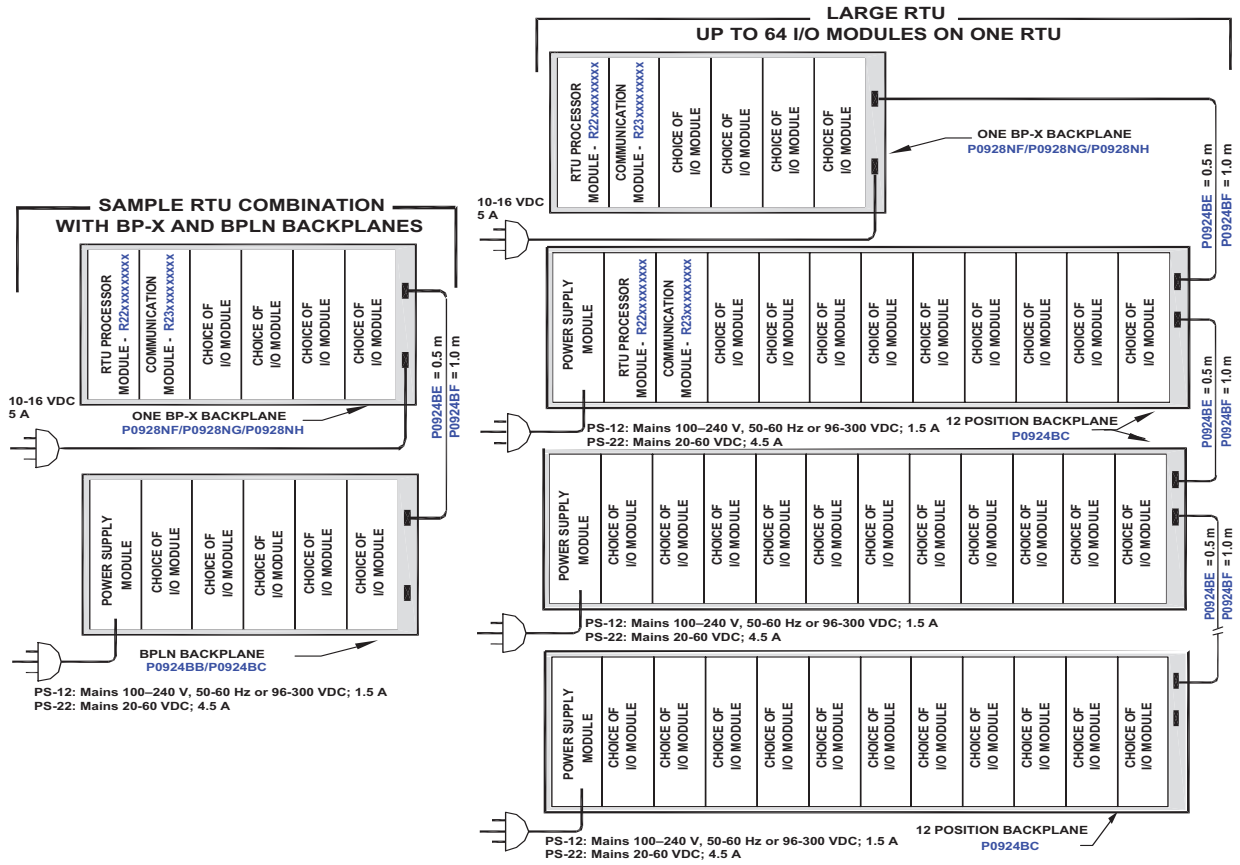

Figure 12. Possible RTUs Using a BP-x Backplane

FUNCTIONAL SPECIFICATIONS

CP-3 Module

PROCESSOR

ARM9 processor operating at 166 MHz
64 MB SDRAM
16 MB Flash
512 KB of battery backed CMOS static RAM.
Real Time Clock
10/100 Mbits/s Ethernet Interface
2 optional ports for communication options

MC-31 Module

ETHERNET COMMUNICATIONS

10/100BaseT
PPP Dial via D option

OPTIONAL COMMUNICATIONS BOARDS FOR CP-3 OR MC31 MODULE

OPT D: V.34 PSTN Dial
OPT F: Serial over optical
OPT H: Hart Bell 202 - 1 to 15 devices multi-drop
OPT I: Isolated serial (RS-232, RS-485, RS-422)
OPT II: Isolated Dual Channel serial port-option board [RS-232, RS-485, RS-422]
OPT L: V.23 2/4 wire for leased line and packet data radio interface support
OPT R2: Spread Spectrum 900 MHz Australian version
OPT R3: SpreadSpectrum 2.4 GHz International version, available on Port 3
OPT R4: Spread Spectrum 900 MHz US version
OPT T3: 10/100BaseT Ethernet (CP3 or MC31 only)

Communication

Modbus protocol interface (RS-232-C/RS-485, ASCII and binary and Modbus TCP)
DNP3 master and slave interface (RS-232-C/RS-485, RS-422, TCP/IP, and UDP) with DNP3 Secure Authentication 2.0
P6008 protocol interface (RS-232-C/RS-485, ASCII and binary)
Terminal Server (on OPT I: Isolated serial (RS-232, RS-485, RS-422) card only)
Five serial communication modules each with two ports either RS-232-C and/or RS-485 interface [Max 17 ports]
Asynchronous communication

Automatic dialing/answer in switched network mode
Master/slave RTUs dial
Transmission rate from 300 to 115 kbps

I/O Modules

AI-10

8 Channel Analog Inputs

5 kV field to logic isolation
0 to 20 mA; 4 to 20 mA current signals [Software Select]
+/- 2.5 V, +/-5 V, and +/-10 V bipolar voltage ranges [Software Select]
16-bit resolution
0.1% accuracy @ 25°C
1 ms per channel internal scanning to filter out noise more effectively
Allows voltage and/or current inputs through the Jumpers
Consumes less power

AO-3

4 Channel Analog Outputs with Open Loop Detection

0 to 20 mA; 4 to 20 mA outputs
12-bit digital-to-analog converter resolution
0.2% accuracy @ 25°C
3 kV Isolation

DI-5

16 Channel Digital Inputs / 4 counters

One common per eight channels
1.5 kV isolation
Isolated Output to power inputs
16-bit Pulse Counting on Channels 1 - 4
Frequency Counting:
Channels 1 and 2 - 10 KHz maximum
Channels 3 and 4 - 255 Hz maximum
Positive or Negative Polarity Inputs

FUNCTIONAL SPECIFICATIONS (CONTINUED)

DI-10

16 Channel Digital Inputs / Counters
 Opt-isolated inputs for 24 V_{DC} contacts,
 3 kV Isolation
 Opt-isolated pulse inputs for 24 V_{DC}
 contacts
 16-bit/counter resolution:
 All channels at 10 KHz resolution
 Also supports AC inputs (20 to 125 V_{AC}) and
 DC inputs (+6 to 130 V_{DC})
 Input voltage thresholds are now compatible
 with IEC 61131-2 Type 1 and Type 3.

DO-1

8 Channel Digital Outputs
 SPDT/SPST relays contacts
 5A @ 30 V_{DC} output (maximum) for each
 contact
 Check-before-operate, protocol dependent

DO-2

16 Channel Digital Outputs
 SPDT/SPST relays contacts
 5 A @ 30 V_{DC} output (maximum) for each
 contact
 Check-before-operate, protocol dependent

DO- 6

16 Channel Relay Driver
 Open drain N-FET outputs
 Rated load 70 mA per channel, 30 V_{DC}
 maximum

IO-3

Multi - IO Module
 AI: 4 x (0 to 20 mA; 4 to 20 mA; 0 to 5 V;
 1 to 5 V) inputs
 DI: 4 x (1 kV Isolated) inputs
 AO: 1 x (0 to 20 mA; 4 to 20 mA) outputs
 DO: 4 x SPST contacts outputs

IO-5

Multi - IO Module
 AI: 4 x (0 to 20 mA; 4 to 20 mA; 0 to 5 V;
 1 to 5 V) inputs
 DI: 4 x (5 kV Isolated, sinking) inputs
 AO: 1 x (0 to 20 mA; 4 to 20 mA) outputs
 DO: 4 x (3 kV Isolated, solid state, sinking)
 outputs

Power Supply Modules

PS-12 AC INPUT POWER SUPPLY

90 to 260 V_{AC} input, from 48 to 62 Hz, with
 battery charger providing 12 V_{DC} floating
 connection
 Also supports 96 to 340 V_{DC}
 Supplies 5A of output current to a 5V backplane
 Total output power is linearly derated to 30 W
 from +65°C to +85°C (derating factor is 1.5 W/°C
 above +65°C)
 5 V_{DC} output is linearly derated to 4.0 A from
 +60°C to +85°C (derating factor is 40 mA/°C
 above +60°C)
 24 V_{DC} output is linearly derated to 100 mA from
 +70°C to +85°C (derating factor is 10 mA/°C
 above +70°C)

PS-22 DC INPUT POWER SUPPLY

24 V_{DC} input, positive/negative/floating
 grounded, with battery charger providing 12 V_{DC}
 floating connection
 5 V_{DC} output is linearly derated to 4.0 A from
 +60°C to +85°C (derating factor is 40 mA/°C
 above +60°C)
 24 V_{DC} output is linearly derated to 100 mA from
 +70°C to +85°C (derating factor is 10 mA/°C
 above +70°C)

ISOLATION TESTS PERFORMED

High voltage isolation

Common mode:

1,500 V - single pulse 1.2 μs/50 μs

Differential mode:

1,500 V - single pulse 1.2 μs/50 μs

Isolation resistance

> 100 MΩ

Regulatory Compliance

ELECTROMAGNETIC COMPATIBILITY (EMC)

European EMC Directive 2014/30/EU

Meets: EN61326-1:2013 Class A Emissions and Industrial Immunity Levels

PRODUCT SAFETY

NRTL Certified compliant to UL 60950-1 and CSA C22.2 No. 60950-1

Low Voltage Directive 2014/35/EU

Meets EN60950-1:2013

To obtain details on product safety, contact the Schneider Electric sales team.

MODULE ENVIRONMENTAL SPECIFICATIONS

Operating

TEMPERATURE

-40 to +85°C (-40 to +185°F)

For modules:

BPLN-12, BPLN-4, BPLN-6, BP-6, BP-4, BP-2, PS-12-C, PS-22-C, PS-12-0, PS-22-0, AI-10-1, AI-10-V, DI-5, DI-10, DO-1, DO-2, DO-6, AO-3, IO-3, IO-5, CP-3, MC-31, COM I, COM II, COM F, COM H, COM T3, and COM L

-20 to +70°C (-4 to +158°F)

For modules:

COM D, COM R2, COM R3, and COM R4

RELATIVE HUMIDITY

5 to 95% (noncondensing) at 40°C (104°F)

ALTITUDE

0 to 2,000 m (0 to 6562 ft)

Storage

TEMPERATURE

-40 to +85°C (-40 to +185°F)

RELATIVE HUMIDITY

5 to 95% (noncondensing) at 40°C (104°F)

Vibration

5.0 m/s² (0.5 g) from 5 to 500 Hz

PHYSICAL SPECIFICATIONS

Modules

MOUNTING

Mount onto a modular backplane.

WEIGHT

284 g (10 oz) approximate

454 g (16 oz) approximate (Power Supply only)

DIMENSIONS

HEIGHT

174 mm (6.9 in)

WIDTH

35 mm (1.4 in)

DEPTH

156 mm (6.1 in)

Backplanes

Backplanes are designed for surface mounting and include mounting brackets (2 pieces).

- ▶ Mounting brackets are used to mount any of the following in a 19-inch rack:
 - One 6-slot backplane (6 BPLN or BP-6)
 - Two 4-slot backplanes (4 BPLN or BP-4)
 - One 2-slot backplane (BP-2) and one 4-slot backplane (4 BPLN)
- ▶ Wing rack brackets are used to mount the 12-slot backplane (12 BPLN) in a 19-inch rack.

BPLN BACKPLANES

Configurations

Support 4, 6, or 12-slot configurations
Can link multiple backplanes with up to 64 modules

Dimensions

HEIGHT
176 mm (6.9 in)
WIDTH
4-slot 194 mm (7.6 in)
6-slot 266 mm (10.5 in)
12-slot 482 mm (19.0 in)
DEPTH
22 mm (0.9 in)

BP-X BACKPLANES

Configurations

Support 2, 4, or 6-slot configurations
One BP-x backplane per RTU, can link multiple BPLN backplanes with up to 64 modules

Dimensions

HEIGHT
176 mm (6.9 in)
WIDTH
2-slot 122 mm (4.8 in)
4-slot 194 mm (7.6 in)
6-slot 266 mm (10.5 in)
DEPTH
22 mm (0.9 in)

DIMENSIONS - NOMINAL

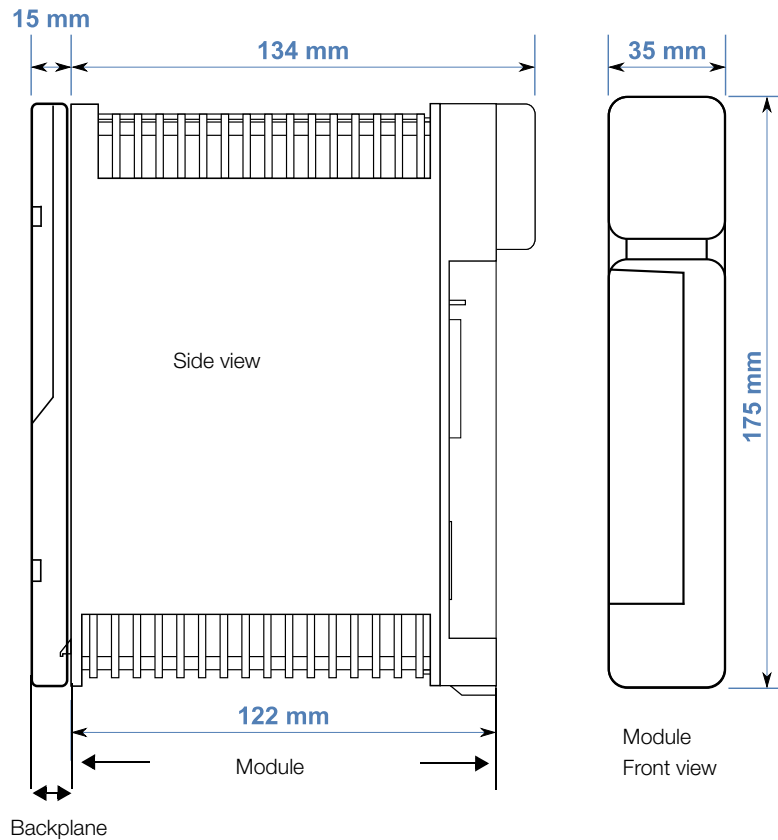

Figure 13. Module Mounted on a Backplane

DIMENSIONS - NOMINAL (CONTINUED)

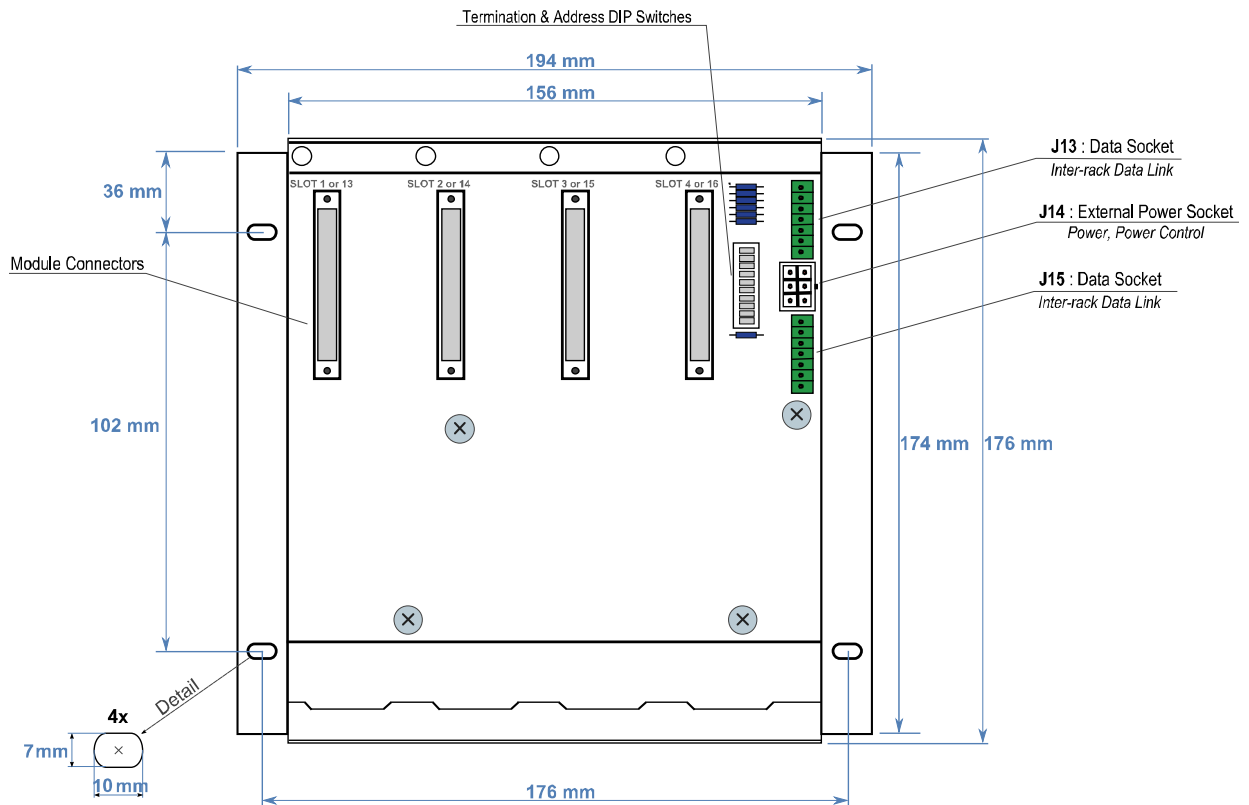

Figure 14. 4-Slot Passive Backplane

DIMENSIONS - NOMINAL (CONTINUED)

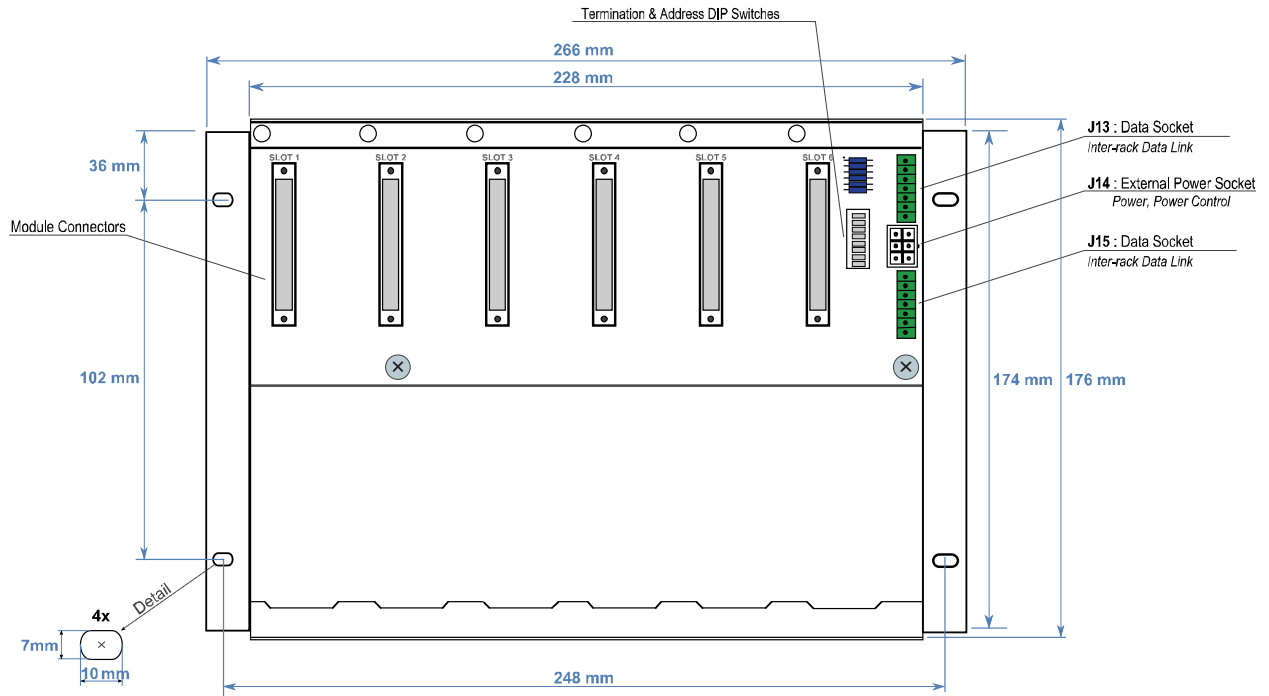

Figure 15. 6-Slot Passive Backplane

DIMENSIONS - NOMINAL (CONTINUED)

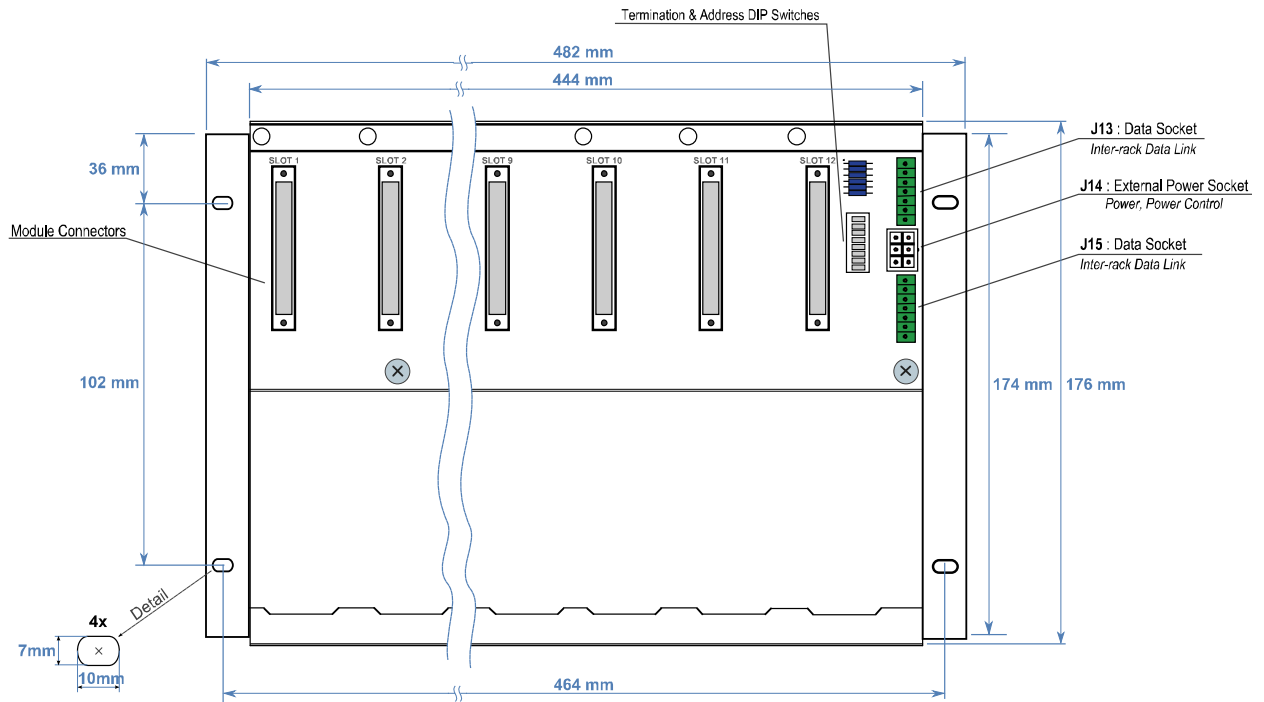

Figure 16. 12-Slot Passive Backplane

DIMENSIONS - NOMINAL (CONTINUED)

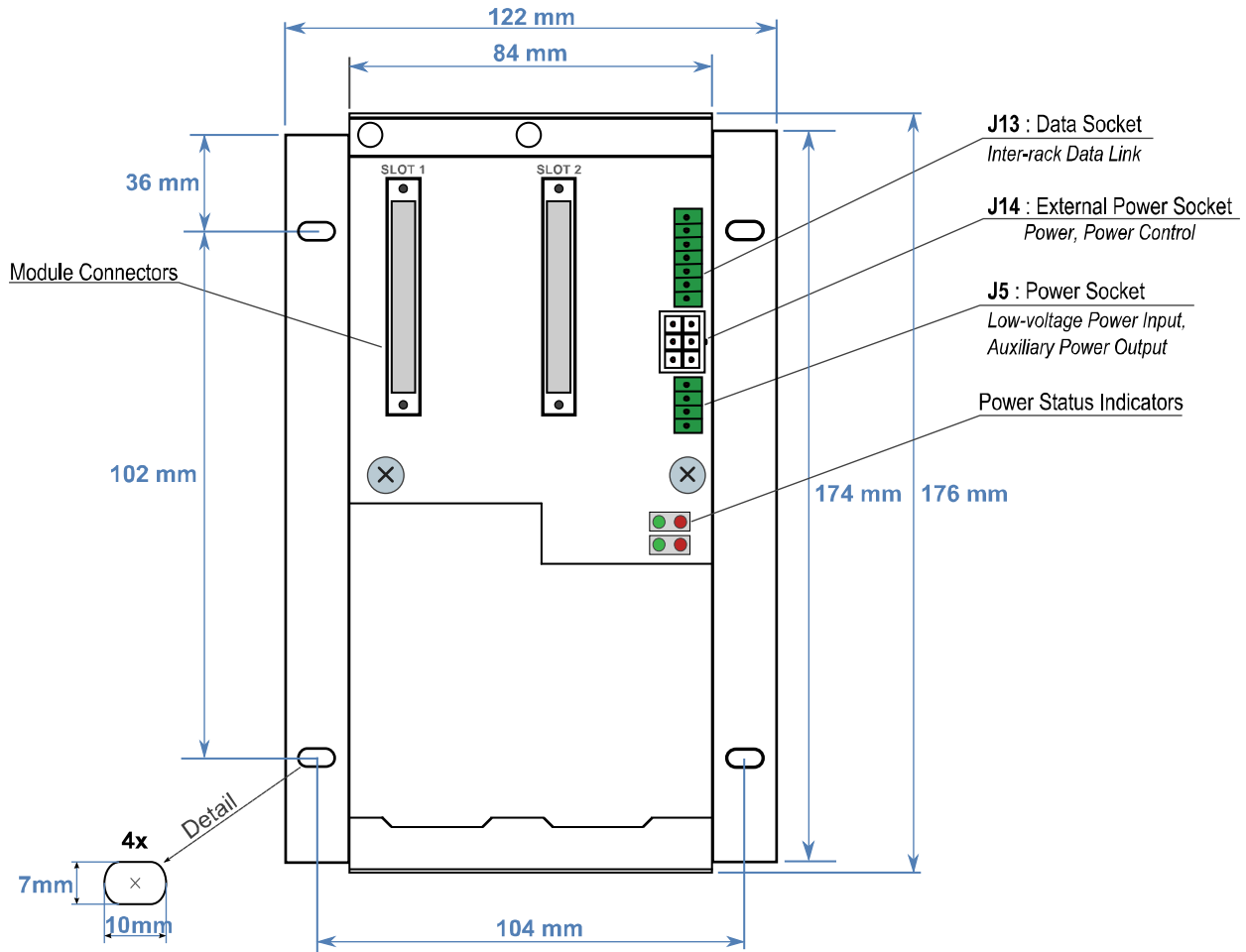

Figure 17. 2-Slot Integrated-power Backplane

DIMENSIONS - NOMINAL (CONTINUED)

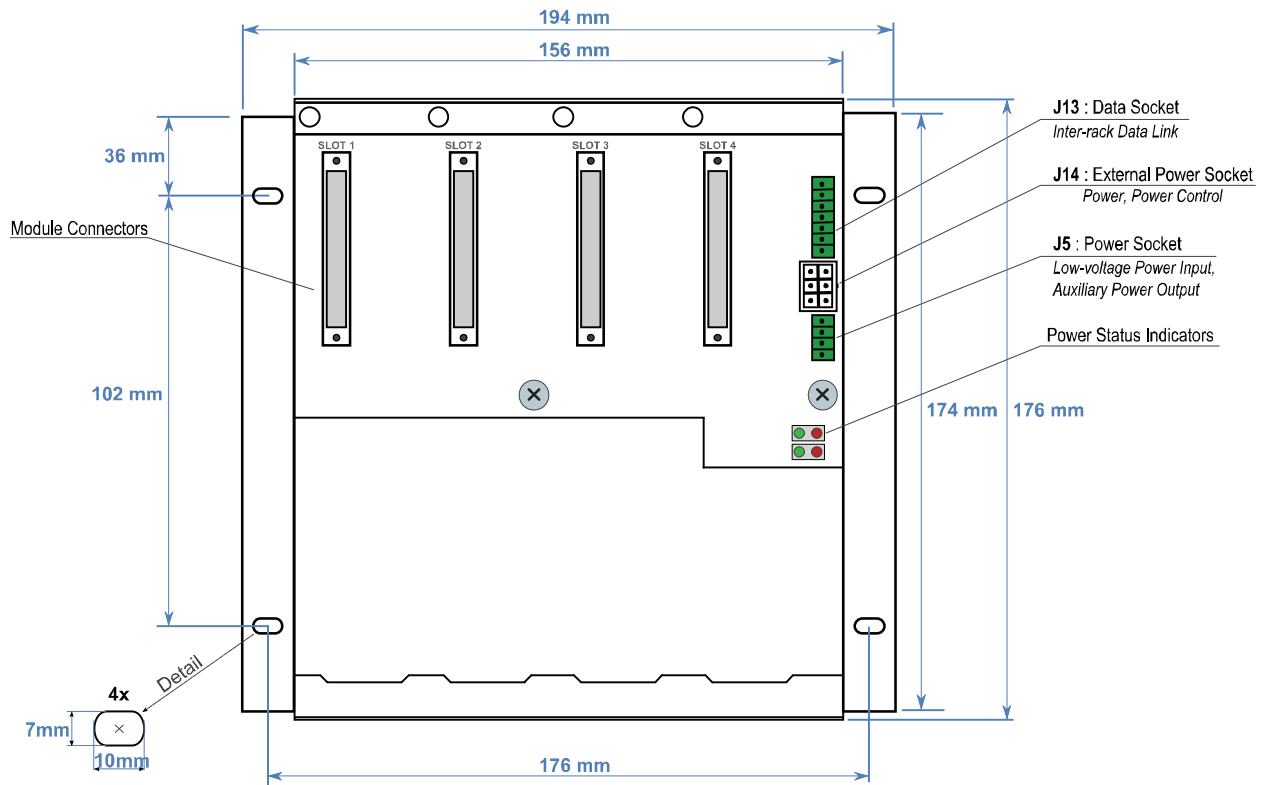

Figure 18. 4-Slot Integrated-power Backplane

DIMENSIONS - NOMINAL (CONTINUED)

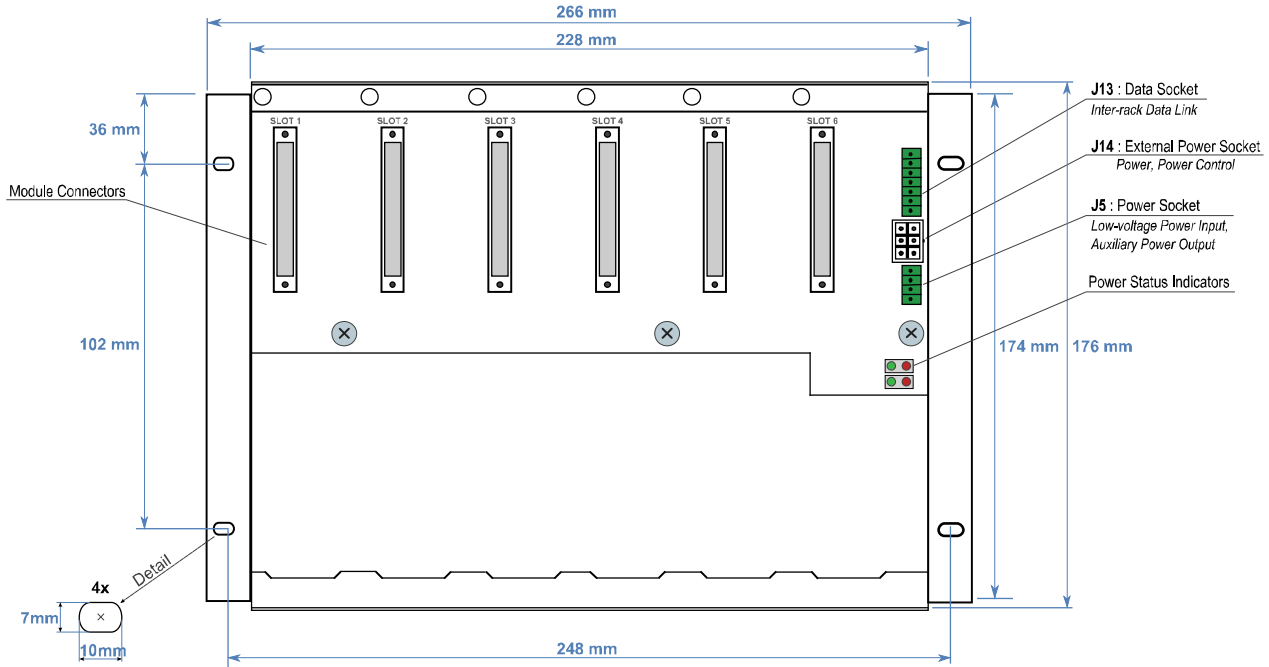

Figure 19. 6-Slot Integrated-power Backplane

ORDERING INFORMATION

Part Number	Description	HW Version Number	Operating Temperature Range
R22	CP-3: SCD2200 Model RTU Processor Module	2.3.A	-40°C to +85°C
R23	MC-31: SCD2200 Model RTU Communications Module	2.3.A	-40°C to +85°C
P0924AC	Communication option D board for CP-3/MC-31; V34 38.4 kbps dialup modem	1.1	-20°C to +70°C
P0924AD	Communication option F board for CP-3/MC-31; Fiber optic - ST connectors - 115 Kbps, option port 2/3 & LP-1	1.0	-40°C to +85°C
P0924AE	Communication option H board for CP-3/MC-31; HART Interface (Limited functionality-refer to specification)	1.2.A	-40°C to +85°C
P0924AF	Communication option I board for CP-3/MC-31; isolated RS232/422/485	1.0.A	-40°C to +85°C
P0928RP	Communication Option II board for CP - 3/MC -31; Dual Isolated serial port RS232/485/422	1.1	-40°C to +85°C

Part Number	Description	HW Version Number	Operating Temperature Range
P0924AH	Communication option L board for CP-3/MC-31; 2/4-wire V.23 interface, 1200 bps	1.2.A	-40°C to +85°C
P0924AJ	Communication option R2 (Australia) board for CP-3/MC-31; Spread Spectrum 900MHz Australian version	2.1	-20°C to +70°C
P0924AK	Communication option R3 (US) board for CP-3/MC-31; Spread Spectrum 2.4GHz International version	2.1	-20°C to +70°C
P0924AL	Communication option R4 (INT) board for CP-3/MC-31; Spread Spectrum 900MHz US version	2.1	-20°C to +70°C
P0924XX	Communication option T3 board for CP-3/MC-31; Ethernet; RJ-45 - 10/100 Mbit (New)	1.2.A	-40°C to +85°C
P0924XU	PS-12-0: Power supply (100-240 V _{AC} input) includes monitoring processor	1.6.A	-40°C to +85°C
P0924XV	PS-22-0: Power supply (20-60 V _{DC} input) includes monitoring processor	1.6.A	-40°C to +85°C
P0928CR	PS-12-C: Power supply (100-240 V _{AC} input) with auxiliary 24 V	1.6.A	-40°C to +85°C
P0928CS	PS-22-C: Power supply (20-60 V _{DC} Input) with auxiliary 24 V	1.6.A	-40°C to +85°C
P0924AS	AI-10-1: I/O Module - 8 analog inputs	2.2.A	-40°C to +85°C
P0924UM	AI-10-V: Analog Input - 8 channel, Voltage Mode	2.2.A	-40°C to +85°C
P0924CV	AO-3: Analog Output - 4 channel, 12 bit resolution with open circuit detection	1.2.A	-40°C to +85°C
P0924AU	DI-10: Digital Input - 16 channel (6-130 V _{DC} , 20-260 V _{AC})	4.3.A	-40°C to +85°C
P0924AV	DO-1: Digital Output - 8 channel (N.O. & N.C. contacts)	2.3.A	-40°C to +85°C
P0924AW	DO-2: I/O Module - 16 Single Pole/Normally Open, relay outputs	2.2	-40°C to +85°C
P0924AX	DO-6: I/O Module -16 digital, relay driver (open drain) outputs	1.2.A	-40°C to +85°C
P0924AY	IO-3: I/O Module - 4 analog inputs, 4 digital inputs, 4 relay outputs, 1 analog output	1.3	-40°C to +85°C
P0924XW	IO-5: Combinational Analog/Digital I/O Module - 4 sinking solid state outputs, 4 digital inputs, 4 analog inputs, 1 analog output with open line detection	1.3A	-40°C to +85°C
P0924CJ	DI-5: Digital Input - 16 channel (12-24 V _{DC})	1.6.A	-40°C to +85°C
P0924BA	4 BPLN: 4 slot backplane	3.2	-40°C to +85°C

Part Number	Description	HW Version Number	Operating Temperature Range
P0924BB	6 BPLN: 6 slot backplane	3.2	-40°C to +85°C
P0924BC	12 BPLN: 12 slot backplane	3.2	-40°C to +85°C
P0928NF	BP-2: 2-slot backplane with integrated power supply	1.5.A	-40°C to +85°C
P0928NG	BP-4: 4-slot backplane with integrated power supply	1.5.A	-40°C to +85°C
P0928NH	BP-6: 6-slot backplane with integrated power supply	1.5.A	-40°C to +85°C
P0924BD	19" rack wings for BA-12 (suit 19" rack mounting)	0	-40°C to +85°C
P0924CD	Bracket for mounting BA-40/BA-6 in 19" rack for SCD2200	0	-40°C to +85°C
P0924BE	Baseplate Connection Cable - 0.5 m	N/A	-40°C to +85°C
P0924BF	Baseplate Connection Cable - 1.0 m	N/A	-40°C to +85°C
P0924BG	Interrack 6 way Power Cable - 0.6 m	N/A	-40°C to +85°C
P0924BH	Interrack 6 way Power Cable - 1.1 m	N/A	-40°C to +85°C
P0924BJ	Cable to connect SS wireless card to yagi antenna	N/A	-20°C to +70°C
P0924BK	PC/Serial Port adapter for I and S options	N/A	0°C to +70°C
K0201BU	FoxRTU Station Media Kit for 64 points - (c/w USB Dongle and 2m Ethernet x-over cable)	N/A	N/A
K0201BX	FoxRTU Station with ISaGRAF 5 - 256 points - (c/w USB Dongle and 2m Ethernet x-over cable)	N/A	N/A
K0201BY	FoxRTU Station with ISaGRAF 5 - 1024 points - (c/w USB Dongle and 2m Ethernet x-over cable)	N/A	N/A
K0201BZ	FoxRTU Station with ISaGRAF 5 - Unlimited points - (c/w USB Dongle and 2m Ethernet x-over cable)	N/A	N/A
K0201CA	FoxRTU Station Media Kit for maintenance personnel	N/A	N/A