



## Foxboro™ DCS

### Compact FBM208, Redundant with Readback, 0 to 20 mA I/O Module

#### PSS 41H-2C208

#### Product Specification

August 2019



# Legal Information

The Schneider Electric brand and any trademarks of Schneider Electric SE and its subsidiaries referred to in this guide are the property of Schneider Electric SE or its subsidiaries. All other brands may be trademarks of their respective owners.

This guide and its content are protected under applicable copyright laws and furnished for informational use only. No part of this guide may be reproduced or transmitted in any form or by any means (electronic, mechanical, photocopying, recording, or otherwise), for any purpose, without the prior written permission of Schneider Electric.

Schneider Electric does not grant any right or license for commercial use of the guide or its content, except for a non-exclusive and personal license to consult it on an "as is" basis. Schneider Electric products and equipment should be installed, operated, serviced, and maintained only by qualified personnel.

As standards, specifications, and designs change from time to time, information contained in this guide may be subject to change without notice.

To the extent permitted by applicable law, no responsibility or liability is assumed by Schneider Electric and its subsidiaries for any errors or omissions in the informational content of this material or consequences arising out of or resulting from the use of the information contained herein.

# Overview

Single input/single output control schemes with high availability requirements can take advantage of the modules arranged as a redundant pair. A readback feature is provided that detects failures of the output channel. In a repair situation, when a single module is replaced, the inputs and outputs are maintained by the redundant module. HART® signals are electrically compatible with the 4-20 mA signals, permitting the plant to upgrade field devices without the need to change the control system.

A redundant pair of the Compact FBM208s combine to provide redundancy at the Fieldbus Module (FBM) level, with field I/O wired to one common termination assembly (see *Figure 1*). Each module independently attempts to hold the output(s) at its specified output value(s), and each independently reports its observed value of the inputs.

A redundant analog input and redundant analog output block in the Foxboro™ DCS Control Software validates each input and output in conjunction with information to/from the module.

The FBM208 is electrically compatible with standard HART signals.

## Features

- Four 0 to 20 mA dc analog input channels
- Four 0 to 20 mA dc analog output channels with readback
- Compares FBM's output value with the current readback value. If the readback value differs from the desired output by more than  $\pm 2\%$ , the FBM marks it's output channel BAD
- Monitors FBM's internal channel current loop power and marks the channel BAD if power is less than 16 V dc
- Marking a channel Bad causes the corresponding channel in the redundant module to continue to drive the outputs
- Redundant modules increase reliability
- Termination Assemblies (TAs) for locally or remotely connecting field wiring to the Compact FBM208

## Readback

The Compact FBM208 compares its output value with the current readback value. If the readback value differs from the desired output by more than  $\pm 2\%$ , the FBM marks its output channel BAD. In addition, if the output value is greater than the desired output by more than  $+2\%$ , the power to that channel is shut off to help prevent the bad channel from interfering with the control of that channel by the redundant partner FBM. The power to a failed channel remains off until the FBM is replaced or rebooted by the user.

When the FBM's output channel is marked BAD, the CP presents that information to the Foxboro DCS for display as a System Management alarm message and as a control block alarm.

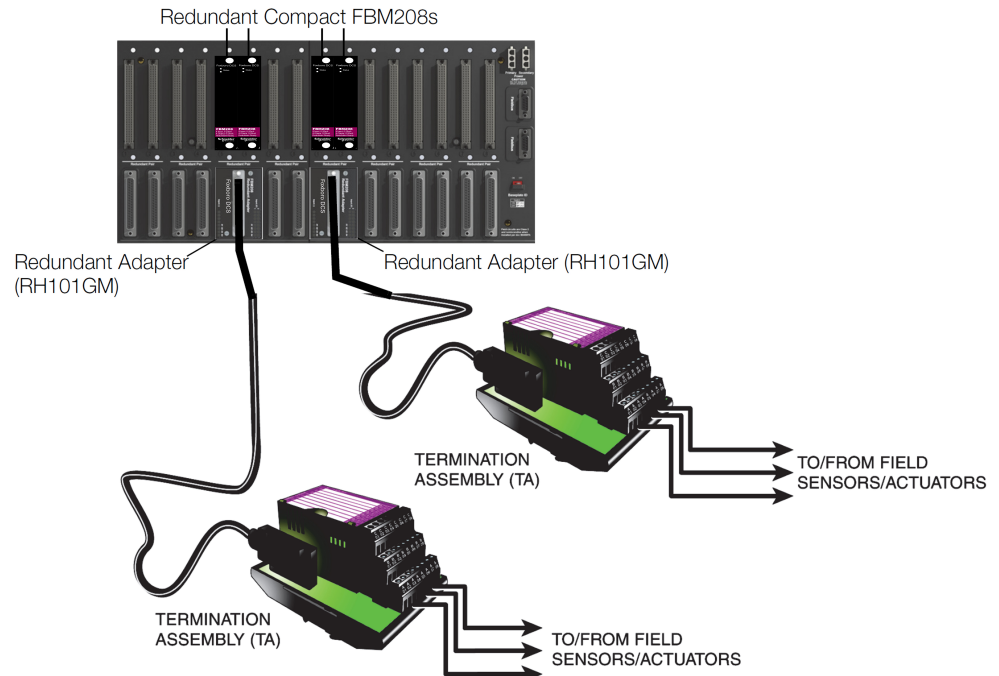
**Figure 1 - Redundant Compact FBM208 I/O Configuration (Two Pairs Shown)**

## Redundant Analog Inputs

Each input channel accepts an analog sensor input such as a 4 to 20 mA transmitter or a self-powered 4 to 20 mA source.

Transmitter power from each module is diode OR'd together in the redundant adapter to help assure redundant power.

A redundant analog input function block, AINR, is used for each redundant pair of inputs. The AINR block handles input reads and initialization logic for the redundant channels. On each execution cycle of the AINR block, identical reads are sent to both modules, fully exercising the fieldbus and the logic circuitry of each module.

Input channel options include a configurable choice of integration time on a per module basis. Input channel security is enhanced by redundantly powering the input current loop from per channel power supplies in each module of the pair.

## Redundant Analog Outputs

Each output channel drives an external load and produces a 0 to 20 mA output.

A redundant analog output block, AOATR, is used for each redundant pair of outputs. The AOATR block handles output writes and initialization logic for the redundant channels. On each execution cycle of the AOATR block, identical output writes are sent to both modules, fully exercising the fieldbus and the logic circuitry of each module. When a failure is detected in one of the modules, its output is driven to 0 mA and the corresponding channel in the good module automatically continues supplying the proper current to the output current loop.

Configurable options in the modules for output failsafe and fallback options are always set to their default values (0 mA). This removes one of the pair of redundant output channels from service for detectable problems such as a module not properly receiving output writes or not passing diagnostic tests on FBM microprocessor writes to output registers. Using the default failsafe/fallback options of 0 mA output also minimizes the possibility of a “fail high” result.

## High Accuracy

For high accuracy, the module incorporates a separate sigma delta converter for each input channel. This can provide new analog input readings every 25 ms, and a configurable integration period to remove any process noise and power line frequencies. Each update time period, the FBM converts each analog input to a digital value, averages these values over the time period and provides the averaged value to the controller.

## High Reliability

The redundancy of the module pair, coupled with the high coverage of detected faults, provides a very high subsystem availability time.

The microprocessor of each module executes the analog I/O application program, plus diagnostic routines that validate the health of the FBM.

Either module may be replaced without upsetting field input or output signals to the good module. The module can be removed/replaced without removing field device termination cabling, power, or communications cabling.

Light-emitting diodes (LEDs) incorporated into the front of the module provide visual indications of the module's operational status.

## Compact Design

The Compact FBM208's design is narrower than the standard 200 Series FBMs, with a rugged Acrylonitrile Butadiene Styrene (ABS) exterior for physical protection of the circuits.

Enclosures specially designed for mounting the FBMs provide various levels of environmental protection, up to harsh environments (Class G3), per ISA Standard S71.04.

## Fieldbus Communication

The Fieldbus Communications Module (FCM) or the Field Control Processor (FCP) interfaces to the redundant 2 Mbps module Fieldbus used by the FBMs. The Compact FBM208 accepts communication from either path (A or B) of the 2 Mbps Fieldbus. If one path is unsuccessful or is switched at the system level, the module continues communication over the active path.

## Modular Baseplate Mounting

The modules mount on a Compact 200 Series baseplate which is either DIN rail mounted or rack mounted horizontally, and includes signal connectors for redundant Fieldbus, redundant independent dc power, and termination cables. Two screws on each FBM fix the module to the Compact 200 Series baseplate.

Redundant modules must be located in adjacent positions on the baseplate, with the first module located in an odd-numbered position (for example, the positions labelled “3” and “4”). To achieve redundancy, a redundant adapter module is placed on the two adjacent baseplate termination cable connectors to provide termination for a single cable (see *Figure 1, page 4*). A single termination cable connects from the redundant adapter to the associated termination assembly (TA).

## Easy Removal/Replacement

When redundant, either module may be replaced without upsetting field input signals to the good module. Each module can be removed/replaced without removing field termination cabling, power, or communications cabling.

## Redundant Modules in Foxboro DCS HMI

The redundant pair of modules appear as two independent modules to system management software applications, such as Foxboro DCS System Manager and System Manager/Display Handler (SMDH). The functional redundancy for these modules is provided by their associated control blocks.

## Termination Assemblies

Field I/O signals for the Compact FBM208 connect to the FBM subsystem via DIN rail mounted TAs. The TAs used with the Compact FBM208 are described in *Termination Assemblies and Cables, page 13*.

## Functional Specifications

Process I/O Communications	Communicates with its associated FCM or FCP via the redundant 2 Mbps module Fieldbus
Input/Output Channels	Four 0 to 20 mA dc analog input channels and four 0 to 20 mA dc analog output channels. Each channel is isolated and independent. <b>NOTE:</b> Redundant pairs (input or output) are connected together by a common field I/O connector and therefore are not isolated from each other.
Input/Output Range (Each Channel)	0 to 20.4 mA dc
Input Channels (Four)	<ul style="list-style-type: none"> <li>• Accuracy (Includes Linearity): ±0.03% of span, which includes the tolerance of the sense resistor in the redundant adapter.</li> <li>• Accuracy Temperature Coefficient: ±50 ppm/°C</li> <li>• Input Signal A/D Conversion: Each channel performs A/D signal conversion using an independent Sigma-Delta converter.</li> <li>• Input Channel Impedance: 60 Ω nominal (resistor in redundant adapter)</li> <li>• Integration Period: Software configurable</li> <li>• Common Mode Rejection: &gt;100 db at 50 or 60 Hz</li> <li>• Normal Mode Rejection: &gt;95 db at 50 or 60 Hz</li> <li>• Loop Power Supply Protection: Each channel is channel-to-channel galvanically isolated, current limited, and voltage regulated. All analog inputs are limited by their design to less than 30 mA. If the current limit circuit shorts out, the current is limited to about 100 mA.</li> <li>• Field Device Cabling Distance: Maximum distance of the field device from the FBM is a function of compliance voltage (22.8 V dc), wire resistance, and voltage drop at the field device.</li> </ul>

<p>Output Channels (Four)</p>	<ul style="list-style-type: none"> <li>• Analog Accuracy: ±0.05% of span</li> <li>• Output Load: 750 Ω maximum</li> <li>• Output Processing Delay: 30 ms maximum</li> <li>• Resolution: 13 bits</li> <li>• Field Device Cabling Distance: Maximum distance of the field device from the FBM is a function of compliance voltage (19.6 V dc at 20.4 mA), wire resistance, and voltage drop at the field device.</li> <li>• Loop Power Supply Protection: Each channel is channel-to-channel galvanically isolated, current limited, and voltage regulated. All analog outputs are limited by their design to about 25 mA. If the output FET shorts, the output current could increase up to 35 mA. In normal operation the FBM outputs a constant current into a 0 to 750 ohm load.</li> <li>• HART® Protocol Compatibility: The channels meet the impedance requirements for a HART high Impedance Device and can be used in a HART loop without interfering with the HART signals between the field device and a Hand-Held Communicator (HHC). If a FoxCom or HART transmitter is used as an “input device” to the Compact FBM208, a 200 Ω in-line resistor (assembly part number RH902VY) must be added in series with the transmitter.</li> </ul>
<p>Input Channel Isolation</p>	<p>Each channel is galvanically isolated from all other channels and ground. The TA/module withstands, without damage, a potential of 600 V ac applied for one minute between any channel and ground, or between a given channel and any other channel.</p> <div style="border: 1px solid black; padding: 5px; text-align: center;"> <p><b>⚡⚠ DANGER</b></p> <p><b>HAZARD OF ELECTRIC SHOCK, EXPLOSION, OR ARC FLASH</b></p> <p>This does not imply that these channels are intended for permanent connection to voltages of these levels. Exceeding the limits for input voltages, as stated elsewhere in this specification, violates electrical safety codes and may expose users to electric shock.</p> <p><b>Failure to follow these instructions will result in death or serious injury.</b></p> </div>
<p>Calibration Requirements</p>	<p>Calibration of the module and termination assembly is not required.</p>
<p>Power Requirements</p>	<ul style="list-style-type: none"> <li>• Input Voltage Range (Redundant): 24 V dc +5%, -10%</li> <li>• Consumption: 10 W (maximum) total for redundant pair</li> <li>• Heat Dissipation: 7 W (maximum) total for redundant pair</li> </ul>
<p>Regulatory Compliance: Electromagnetic Compatibility (EMC)</p>	<ul style="list-style-type: none"> <li>• <i>European EMC Directive 2004/108/EC (Prior to April 20, 2016) and 2014/30/EU (Beginning April 20, 2016):</i> Meets: EN61326-1:2013 Class A Emissions and Industrial Immunity Levels</li> </ul>



Regulatory Compliance: Product Safety	<ul style="list-style-type: none"><li>• <i>Underwriters Laboratories (UL) for U.S. and Canada:</i> UL/UL-C listed as suitable for use in UL/ULC listed Class I, Groups A-D; Division 2; temperature code T4 enclosure based systems when connected to specified Foxboro DCS processor modules. Communications circuits also meet the requirements for Class 2 as defined in Article 725 of the National Electrical Code (NFPA No.70) and Section 16 of the Canadian Electrical Code (CSA C22.1). For more information, see <i>Standard and Compact 200 Series Subsystem User's Guide</i> (B0400FA).</li><li>• <i>European Low Voltage Directive 2006/95/EC (Prior to April 20, 2016) and 2014/35/EU (Beginning April 20, 2016) and Explosive Atmospheres (ATEX) directive 94/9/EC (Prior to April 20, 2016) and 2014/34/EU (Beginning April 20, 2016):</i> DEMKO certified as Ex nA IIC T4 for use in certified Zone 2 enclosure when connected to specified processor modules as described in the <i>Standard and Compact 200 Series Subsystem User's Guide</i> (B0400FA).</li></ul>
RoHS Compliance	Complies with European RoHS Directive 2011/65/EU, including amending Directives 2015/863 and 2017/2102.

## Environmental Specifications

	Operating	Storage
<b>Temperature</b>	<ul style="list-style-type: none"> <li>• Module: -20 to +60°C (-4 to +140°F)</li> <li>• Termination Assembly — PA: -20 to +70°C (-4 to +158°F)</li> </ul>	-40 to +70°C (-40 to +158°F)
<b>Relative Humidity</b>	5 to 95% (noncondensing)	5 to 95% (noncondensing)
<b>Altitude</b>	-300 to +3,000 m (-1,000 to +10,000 ft)	-300 to +12,000 m (-1,000 to +40,000 ft)
<b>Vibration</b>	7.5 m/s <sup>2</sup> from 5 to 500 Hz	
<b>Contamination</b>	Suitable for use in Class G3 (Harsh) environments as defined in ISA Standard S71.04, based on exposure testing according to EIA Standard 364-65, Class III.	

**NOTE:** The environmental limits of this module may be enhanced by the type of enclosure containing the module. Refer to the applicable Product Specification Sheet (PSS) that describes the type of enclosure to be used.

## Physical Specifications

Mounting	<ul style="list-style-type: none"> <li>• Module: The Compact FBM208 mounts on a Compact 200 Series 16-slot horizontal baseplate. The baseplate can be mounted on a horizontal DIN rail, or horizontally on a 19-inch rack using a mounting kit. Redundant modules must be located in odd and even adjacent positions on the baseplate (positions 1 and 2, 3 and 4, 5 and 6, 7 and 8, 9 and 10 (the second 1 and 2), 11 and 12 (the second 3 and 4), 13 and 14 (the second 5 and 6), or 15 and 16 (the second 7 and 8)). See <i>Compact 200 Series 16-Slot Horizontal Baseplate</i> (PSS 41H-2C200) for details.</li> <li>• Termination Assemblies: The TAs accommodate multiple DIN styles including 32 mm (1.26 in) and 35 mm (1.38 in).</li> </ul>
Weight	<ul style="list-style-type: none"> <li>• Module: 185 g (6.5 oz) approximate</li> <li>• Termination Assemblies: <ul style="list-style-type: none"> <li>◦ Compression Screw Type: 363 g (0.8 lb)</li> <li>◦ Ring Lug Type: 464 g (1.0 lb)</li> </ul> </li> </ul>
Dimensions - Compact FBM208	<ul style="list-style-type: none"> <li>• Height: 130 mm (5.12 in)</li> <li>• Width: 25 mm (0.98 in)</li> <li>• Depth: 150 mm (5.9 in) - Including baseplate connectors, 139 mm (5.46 in)</li> </ul>
Dimensions - Termination Assemblies	See <i>Dimensions - Nominal</i> , page 16.
Part Numbers	<ul style="list-style-type: none"> <li>• Compact FBM208: RH101GE</li> <li>• Termination Assemblies: See <i>Functional Specifications - Termination Assemblies</i>, page 14.</li> <li>• Redundant Adapter: RH101GM</li> </ul>

<p>Termination Cables</p>	<ul style="list-style-type: none"> <li>• Cable Lengths: Up to 30 m (98 ft)</li> <li>• Cable Materials: Polyurethane outer jacket over semi-rigid PVC primary conductor insulation (P/PVC) Polyurethane or Low Smoke Zero Halogen (LSZH)</li> <li>• Termination Cable Type: Type 1 — See <i>Table 2</i></li> <li>• Cable Connection:             <ul style="list-style-type: none"> <li>◦ FBM Baseplate End: 37-pin D-subminiature</li> <li>◦ Termination Assembly End: 25-pin D-subminiature</li> </ul> </li> </ul>
<p>Construction - Termination Assembly</p>	<p>Material:</p> <ul style="list-style-type: none"> <li>• Compression: Polyamide (PA)</li> <li>• Ring Lug: Polyamide (PA)</li> </ul>
<p>Field Termination Connections</p>	<ul style="list-style-type: none"> <li>• Compression Accepted Wiring Sizes:             <ul style="list-style-type: none"> <li>◦ Solid/Stranded/AWG 0.2 to 4 mm<sup>2</sup>/0.2 to 2.5 mm<sup>2</sup>/24 to 12 AWG</li> <li>◦ Stranded with Ferrules 0.2 to 2.5 mm<sup>2</sup> with or without plastic collar</li> </ul> </li> <li>• Ring Lug Accepted Wiring Sizes: #6 size connectors (9.5 mm (0.375 in)) 0.5 to 4 mm<sup>2</sup>/22 AWG to 12 AWG</li> </ul>

# Termination Assemblies and Cables

The Compact FBM208 field I/O signals connect to the FBM subsystem via DIN rail mounted termination assemblies (TAs).

The redundant adapter connects the redundant Compact 200 Series baseplate input/output connectors together. The redundant adapter provides a single termination connection to a single TA (see *Figure 1, page 4*). TAs are available in Polyamide (PA) material.

The DIN rail mounted TAs connect to the redundant adapter by means of a removable termination cable. The cable is available in a variety of lengths, up to 30 meters (98 feet), allowing the TA to be mounted in either the enclosure or in an adjacent enclosure. Termination cables are available in these materials:

- Polyurethane
- Low Smoke Zero Halogen (LSZH)

# Functional Specifications - Termination Assemblies

FBM Type	Input		Output		TA Part No. <sup>(a)</sup>	Termination Type <sup>(b)</sup>	TA Cable Type <sup>(c)</sup>	TA Cert. Type <sup>(d)</sup>
	Qty	Signal	Qty	Signal	PA			
Compact FBM208	4	0 to 20 mA	4	0 to 20 mA	RH916XL	C	1	1, 2
					P0917JP	RL		

- (a) PA is polyamide rated from -20 to +70°C (-4 to +158°F).
- (b) C = TA with compression terminals, RL = TA with ring lug terminals.
- (c) See *Table 2, page 15* for cable part numbers and specifications.
- (d) See *Table 1, page 14* for Termination Assembly certification definitions.

**Table 1 - Certification for Termination Assemblies**

Type	Certification <sup>(a)</sup>
Type 1	TAs are UL/UL-C listed as suitable for use in Class I; Groups A-D; Division 2 temperature code T4 hazardous locations. They are CENELEC (DEMKO) certified Ex nA IIC T4 for use in Zone 2 potentially explosive atmospheres.
Type 2	TAs are UL/UL-C listed for supplying field circuits Class I; Groups A-D; Division 2 hazardous locations when connected to specified 200 Series FBMs and field circuits meeting entity parameter constraints specified in <i>Standard and Compact 200 Series Subsystem User's Guide</i> (B0400FA). They are also DEMKO certified for supplying field circuits for Group IIC, Zone 2 potentially explosive atmospheres. Field circuits are also Class 2 limited energy (60 V dc, 30 V ac, 100 VA or less) if customer-supplied equipment meets Class 2.

**Table 2 - Termination Cable Types and Part Numbers — Type 1**

<b>Cable Length m (ft)</b>	<b>Type 1 P/PVC<sup>(a)</sup></b>	<b>Type 1 LSZH<sup>(b)</sup></b>
0.5 (1.6)	RH100BY	RH100BC
1.0 (3.2)	RH100BZ	RH100BD
1.5 (4.9)	RH100EP	RH100EL
2.0 (6.6)	RH100CA	RH100BE
3.0 (9.8)	RH100CB	RH100BF
5.0 (16.4)	RH100CC	RH100BG
10.0 (32.8)	RH100CD	RH100BH
15.0 (49.2)	RH100CE	RH100BJ
20.0 (65.6)	RH100CF	RH100BK
25.0 (82.0)	RH100CG	RH100BL
30.0 (98.4)	RH100CH	RH100BM
<p><sup>(a)</sup> P/PVC is polyurethane outer jacket and semi-rigid PVC primary conductor insulation. Temperature range: -20 to +80°C (-4 to +176°F).</p> <p><sup>(b)</sup> Low smoke zero halogen or low smoke free of halogen (LSZH) is a material classification used for cable jacketing. LSZH is composed of thermoplastic or thermoset compounds that emit limited smoke and no halogen when exposed to high sources of heat. Temperature range: -40 to +105°C (-40 to +221°F).</p>		

# Dimensions - Nominal

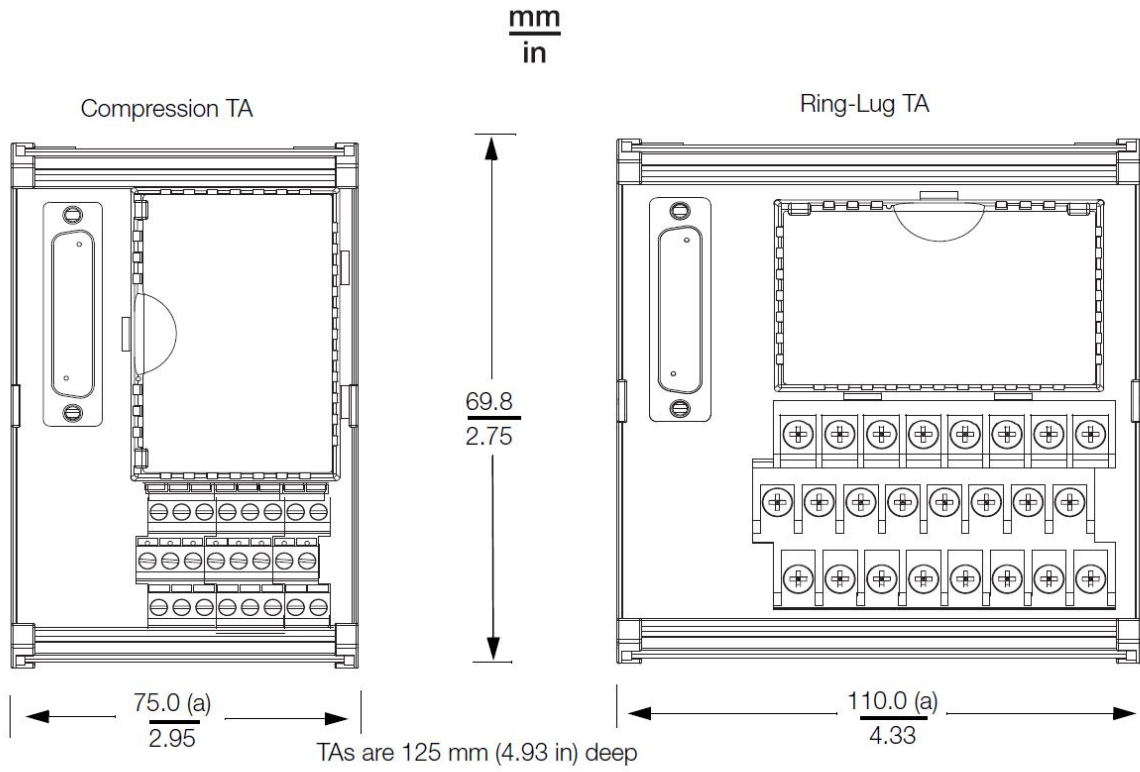

(a) Overall width – for determining DIN rail loading.



## Related Product Documents

<b>Document Number</b>	<b>Description</b>
PSS 41H-2COV	<i>Compact 200 Series I/O Subsystem Overview</i>
B0400FA	<i>Standard and Compact 200 Series Subsystem User's Guide</i>
PSS 41H-2C200	<i>Compact 200 Series 16-Slot Horizontal Baseplate</i>
PSS 41H-2SOV	<i>Standard 200 Series Subsystem Overview</i>
PSS 41H-2CERTS	<i>Standard and Compact 200 Series I/O - Agency Certifications</i>
PSS 41H-2C480	<i>Compact Power Supply - FPS480-24</i>
PSS 41S-3FCPICS	<i>Field Control Processor 280 (FCP280) Integrated Control Software</i>

 **WARNING:** This product can expose you to chemicals including lead and lead compounds, which are known to the State of California to cause cancer and birth defects or other reproductive harm. For more information, go to [www.p65warnings.ca.gov/](http://www.p65warnings.ca.gov/).

Schneider Electric Systems USA, Inc.  
38 Neponset Avenue  
Foxboro, Massachusetts 02035-2037  
United States of America

Global Customer Support: <https://pasupport.schneider-electric.com>

As standards, specifications, and design change from time to time, please ask for confirmation of the information given in this publication.

© 2019 Schneider Electric. All rights reserved.

PSS 41H-2C208, Rev A